

MONSOON

Standard Twin Pumps

MONSOON Standard Twin pumps are designed for installation into vented systems to equally boost both the hot and cold water supplies to the whole house, bathroom or simply the shower.

MONSOON standard pumps require a flow of just 1 litre per minute through either outlet to start the pump and are suitable for positive head applications.



Features

- 5 year warranty
- 1.5 – 4.5 bar options
- Suitable for positive head applications
- Premium quality brass pump supplied with anti-vibration hoses
- Very quiet operation
- WRAS approved product / Kiwa KUKreg4
- Continuously rated
- Anti-vibration feet
- EPDM/PTFE/Al. Oxide seal
- Pre-wired with 1.5 metre power cable
- UK: Supplied with 22mm push-fit x 310mm anti-vibration flexible hoses with integral isolating valves
- ROI: Supplied with 21mm push-fit x 305mm anti-vibration flexible hoses with integral isolating valves
- Export: Supplied with G 3/4F x 318mm anti-vibration flexible hoses

Application

- Boosting hot and cold water supplies to taps, showers, a complete bathroom or the whole house in low pressure open-vented / gravity systems
- Suitable for use where there is already more than 2 litre/min flow from the outlet(s) to be boosted

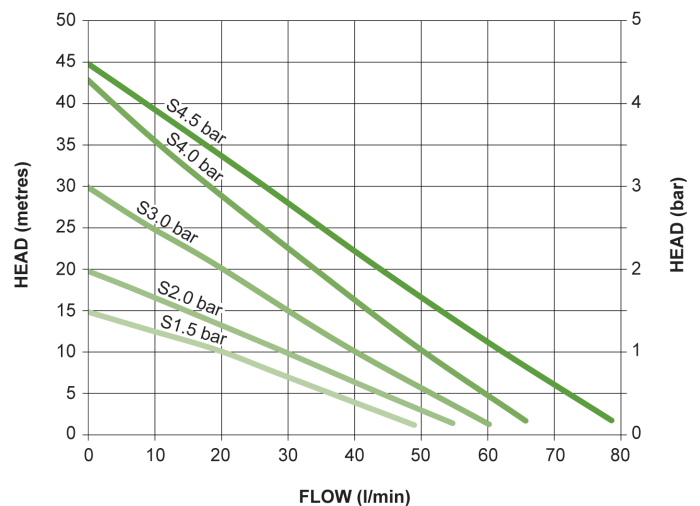

		S1.5 bar Twin 46506	S2.0 bar Twin 46415	S3.0 bar Twin 46416	S4.0 bar Twin 46417	S4.5 bar Twin 46418
GENERAL	Warranty	5 years (subject to conditions)				
	Approval certification	WRAS Approved Product Kiwa UK (KUKreg4)				
	Conformity certification	UKCA CE				
FEATURES	Pump type	Peripheral				
	Pump control	Flow switch				
	Anti-vibration feet	✓	✓	✓	✓	✓
	Inlet strainer(s)	✓	✓	✓	✓	✓
	Flexible hoses	4	4	4	4	4
	Dry run protection	✓	✓	✓	✓	✓
	Typical noise	48 dB(A)	52 dB(A)	54 dB(A)	56 dB(A)	57 dB(A)
PERFORMANCE	Maximum head – closed valve	1.5 bar	2.0 bar	3.0 bar	4.2 bar	4.5 bar
	Performance @ 9 l/min	1.2 bar	1.5 bar	2.5 bar	3.5 bar	3.9 bar
	Performance @ 18 l/min	1.1 bar	1.3 bar	2.1 bar	3.0 bar	3.4 bar
	Maximum flow	49 l/min	55 l/min	60 l/min	65 l/min	78 l/min
	Maximum static inlet pressure	14 metres				
	Maximum working pressure*	600 kPa (6 bar)				
	Maximum ambient air temperature	40 °C				
	Min / Max water temperature**	Min 4 °C / Max 65 °C				
CONSTRUCTION	Enclosure protection	IPX4				
	Pump Body / impeller	Brass				
	Mechanical seal	EPDM / PTFE / Al. Oxide				
CONNECTIONS	Pump connections	G ¾ M				
ANTI-VIBRATION HOSES	Connections (UK model)	G ¾ F x 22 mm push-fit x 310 mm long ± 5mm, isolating valves on all hoses				
	Connections (ROI model)	G ¾ F x 21 mm push-fit x 305 mm long ± 5mm, isolating valves on all hoses				
	Connections (Export model)	G ¾ F x G ¾ F x 318 mm long ± 5mm				
MOTOR	Type	Induction (auto-reset thermal trip)				
	Duty rating	Continuous (S1) @ 9 l/min and above***				
ELECTRICAL	Power supply (Vac/Ph/Hz)	230 V a.c. / 1 / 50 Hz				
	Power consumption – P1	345 Watts	425 Watts	640 Watts	890 Watts	1090 Watts
	Current – full load	1.5 Amps	1.9 Amps	2.8 Amps	4.0 Amps	4.9 Amps
	Fuse rating	5 Amps			13 Amps	
	Power cable length	1.5 metres				
DIMENSIONS	Length	265 mm			300 mm	310 mm
	Width	126 mm				
	Height – excluding hoses	202 mm				
	Weight – including fittings	7.2 Kg		7.6 Kg	9.4 Kg	10.1 Kg

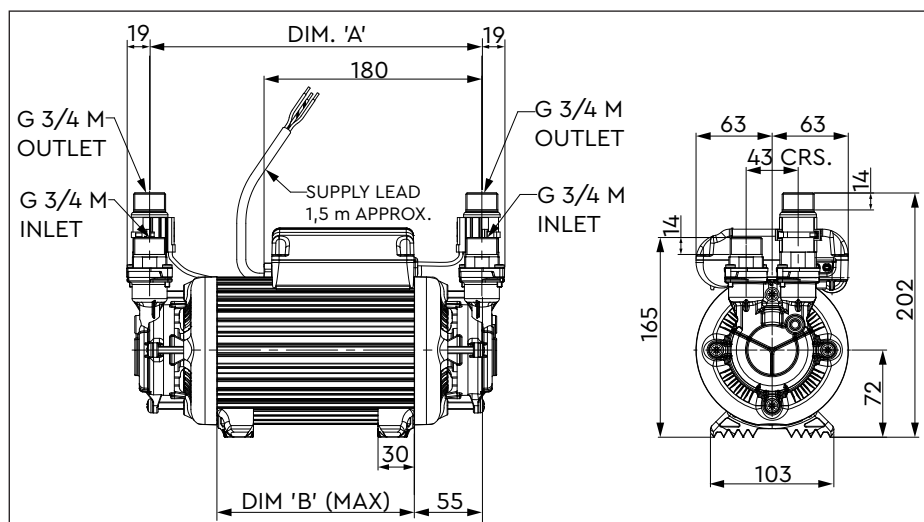

* The maximum pressure that can be applied to the pump under any installation conditions.

** A stored water temperature of 60 °C is considered sufficient to meet all normal requirements and will minimise deposition of scale in hard water areas.

*** Both heads pumping 4.5 l/min and above.

Pump Description	Dim. 'A'	Dim. 'B'
S1.5 bar Twin	227 mm	119 mm
S2.0 bar Twin	227 mm	119 mm
S3.0 bar Twin	227 mm	119 mm
S4.0 bar Twin	262 mm	154 mm
S4.5 bar Twin	272 mm	164 mm

Stuart Turner Limited reserves the right to amend specifications without notice.