

**Project:**  
**Reference Number:**

**Client:**  
**Client Number:**  
**Contact:**

Qty.	Description
1	<p data-bbox="199 436 582 470"><b>TPE3 65-150 S-A-F-I-BQQE-GWB</b></p>  <p data-bbox="590 772 1061 806">Note! Product picture may differ from actual product</p> <p data-bbox="199 817 470 851">Product No.: <a href="#">98416836</a></p> <p data-bbox="199 873 1444 952">Single-stage, close-coupled, volute pump with in-line suction and discharge ports of identical diameter. The pump is of the top-pull-out design, i.e. the power head (motor, pump head and impeller) can be removed for maintenance or service while the pump housing remains in the pipework.</p> <p data-bbox="199 963 1380 1019">The shaft seal is according to EN 12756. Pipework connection is via PN 6/10 DIN flanges (EN 1092-2 and ISO 7005-2).</p> <p data-bbox="199 1019 1452 1075">The pump is fitted with a fan-cooled, permanent-magnet synchronous motor. The motor efficiency is classified as IE5 in accordance with IEC 60034-30-2.</p> <p data-bbox="199 1075 1444 1176">The motor includes a frequency converter and PI controller in the motor terminal box. This enables continuously variable control of the motor speed, which again enables adaptation of the performance to a given requirement. The pump is fitted with a combined temperature- and differential pressure sensor. The stainless-steel pump housing makes the pump suitable for circulation of hot water.</p> <p data-bbox="199 1187 1428 1220">The pump is suitable for applications requiring pressure or temperature control and offers following control modes:</p> <ul data-bbox="239 1243 1460 1646" style="list-style-type: none"> <li>- AUTOADAPT. This function continuously adjusts the proportional-pressure curve and automatically sets a more efficient curve without compromising comfort demands.</li> <li>- FLOWADAPT. This control mode combines AUTOADAPT with a flow-limiting function. The pump continuously monitors the flow rate to ensure the desired maximum flow is not exceeded. This will save the cost of a separate pump-throttling valve.</li> <li>- Constant differential pressure. The pump head is kept constant, independent of the flow in the system.</li> <li>- Proportional pressure. The head of the pump will increase proportionally to the flow in the system to compensate for the large pressure losses in the distribution pipes.</li> <li>- Constant temperature. The return-pipe temperature is kept constant. Note: If the pump is installed in the flow pipe, an external temperature sensor must be installed in the return pipe of the system.</li> <li>- Constant differential temperature. The differential temperature can be measured by a differential-temperature sensor or two separate temperature sensors.</li> <li>- Constant curve. The pump can be set to run at a constant speed in the range of 25 to 100 % of the maximum speed.</li> </ul> <p data-bbox="199 1657 1452 1736">The product's minimum efficiency index (MEI) is greater or equal to 0.70. This is by the Commission Regulation (EU) considered as an indicative benchmark for best-performing water pump available on the market as from 1 January 2013.</p> <p data-bbox="199 1736 1444 1792">The operating panel on the motor terminal box features a four-inch TFT display, push-buttons and the Grundfos Eye indicator.</p> <p data-bbox="199 1792 965 1825">The display gives an intuitive and user-friendly interface to all functions.</p> <p data-bbox="199 1825 1460 1881">The push-buttons are used to navigate through the menu structure to access pump and performance data on site and enable setting of required setpoint as well as setting of pump to "Min." or "Max." operation or to "Stop".</p> <p data-bbox="199 1881 1189 1915">The Grundfos Eye indicator on the operating panel provides visual indication of pump status:</p> <ul data-bbox="239 1915 1460 2072" style="list-style-type: none"> <li>• "Power on": Motor is running (rotating green indicator lights) or not running (permanently green indicator lights)</li> <li>• "Warning": Motor is still running (rotating yellow indicator lights) or has stopped (permanently yellow indicator lights)</li> <li>• "Alarm": Motor has stopped (flashing red indicator lights).</li> </ul>

**Project:**  
**Reference Number:**
**Client:**  
**Client Number:**  
**Contact:**

Qty.	Description
------	-------------

1	<p>Communication with the pump is also possible by means of Grundfos GO Remote (accessory). The remote control enables further settings as well as reading out of a number of parameters such as "Actual value", "Speed", "Power input" and total "Power consumption".</p>
---	--

Cast-iron parts have an epoxy-based coating made in a cathodic electro-deposition (CED) process. CED is a high-quality dip-painting process where an electrical field around the products ensures deposition of paint particles as a thin, well-controlled layer on the surface.

### Pump

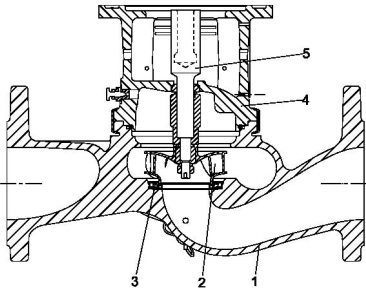

- 1: Pump housing
- 2: Impeller
- 3: Neck ring
- 4: Pump head/motor stool
- 5: Stub shaft

The pump housing is provided with a replaceable stainless steel/PTFE neck ring to reduce the amount of liquid running from the discharge side of the impeller to the suction side.

The impeller is secured to the shaft with a nut.

The pump is fitted with an unbalanced rubber bellows seal with torque transmission across the spring and around the bellows. Due to the bellows, the seal does not wear the shaft, and the axial movement is not prevented by deposits on the shaft.

Seal faces:

- Rotating seal ring material: silicon carbide (SiC)
- Stationary seat material: silicon carbide (SiC)

This material pairing is used where higher corrosion resistance is required. The high hardness of this material pairing offers good resistance against abrasive particles.

Secondary seal material: EPDM (ethylene-propylene rubber)

EPDM has excellent resistance to hot water. EPDM is not suitable for mineral oils.

The motor stool forms connection between the pump housing and the motor, and is equipped with a manual air vent screw for venting of the pump housing and the shaft seal chamber. The sealing between motor stool and pump housing is an O-ring.

The central part of the motor stool is provided with guards for protection against the shaft and coupling. The pump shaft is fastened directly on the motor shaft with key and set screws.

### Motor

The motor is a totally enclosed, fan-cooled motor with principal dimensions to IEC and DIN standards. Electrical tolerances comply with IEC 60034.

The motor efficiency is classified as IE5 in accordance with IEC 60034-30-2.

The motor requires no external motor protection. The motor control unit incorporates protection against slow- and quick-rising temperatures, e.g. constant overload and stalled conditions.

The terminal box holds terminals for these connections:

- one dedicated digital input
- two analog inputs, 0(4)-20 mA, 0-10 V
- one configurable digital input or open-collector output
- Grundfos combined temperature and differential pressure sensor (separate connected)
- 24 V voltage supply for sensors
- two signal relay outputs (potential-free contacts)



**Company name:** national pumps and boilers  
**Created by:**  
**Phone:** 01539 729395  
**Email:** info@nationlapumpsandboilers.co.uk  
**Date:** 02/01/2024

**Project:**  
**Reference Number:**

**Client:**  
**Client Number:**  
**Contact:**

Qty.	Description
1	<ul style="list-style-type: none"> <li>- GENIbus connection</li> <li>- interface for Grundfos CIM fieldbus module.</li> </ul> <p><b>Further product details</b></p> <p>Cast-iron parts have an epoxy-based coating made in a cathodic electro-deposition (CED) process. CED is a high-quality dip-painting process where an electrical field around the products ensures deposition of paint particles as a thin, well-controlled layer on the surface.</p> <p><b>Technical data</b></p> <p>Controls:</p> <p>Frequency converter: Built-in</p> <p>Liquid:</p> <p>Pumped liquid: Water</p> <p>Liquid temperature range: -25 .. 120 °C</p> <p>Selected liquid temperature: 20 °C</p> <p>Density: 998.2 kg/m<sup>3</sup></p> <p>Technical:</p> <p>Pump speed on which pump data are based: 4000 rpm</p> <p>Rated flow: 32.7 m<sup>3</sup>/h</p> <p>Rated head: 9.8 m</p> <p>Actual impeller diameter: 78 mm</p> <p>Code for shaft seal: BQQE</p> <p>Curve tolerance: ISO9906:2012 3B2</p> <p>Materials:</p> <p>Pump housing: Stainless steel EN 1.4308 ASTM CF8</p> <p>Impeller: Composite PES+30% GF</p> <p>Installation:</p> <p>Range of ambient temperature: -20 .. 50 °C</p> <p>Maximum operating pressure: 10 bar</p> <p>Max pressure at stated temp: 10 bar / 120 °C</p> <p>Type of connection: DIN</p> <p>Size of connection: DN 65</p> <p>Pressure rating for connection: PN 6/10</p> <p>Port-to-port length: 340 mm</p> <p>Flange size for motor: 56C</p> <p>Electrical data:</p> <p>Motor type: 80B</p> <p>Rated power - P2: 1.1 kW</p> <p>Mains frequency: 50 / 60 Hz</p> <p>Rated voltage: 1 x 200-240 V</p> <p>Rated current: 6.70-5.60 A</p> <p>Cos phi - power factor: 0.99</p> <p>Rated speed: 360-4000 rpm</p> <p>IE Efficiency class: IE5</p> <p>Motor efficiency at full load: 86.9 %</p>



**Company name:** national pumps and boilers  
**Created by:**  
**Phone:** 01539 729395  
**Email:** info@nationlapumpsandboilers.co.uk  
**Date:** 02/01/2024

**Project:**  
**Reference Number:**

**Client:**  
**Client Number:**  
**Contact:**

Qty.	Description
1	Enclosure class (IEC 34-5): IP55 Insulation class (IEC 85): F Motor No: 99137987  Others: Minimum efficiency index, MEI ≥: 0.70 Net weight: 28.6 kg Gross weight: 37.3 kg Shipping volume: 0.164 m <sup>3</sup> Danish VVS No.: 382143150

**Project:**  
**Reference Number:**

**Client:**  
**Client Number:**  
**Contact:**

## 98416836 TPE3 65-150 S-A-F-I-BQQE-GWB

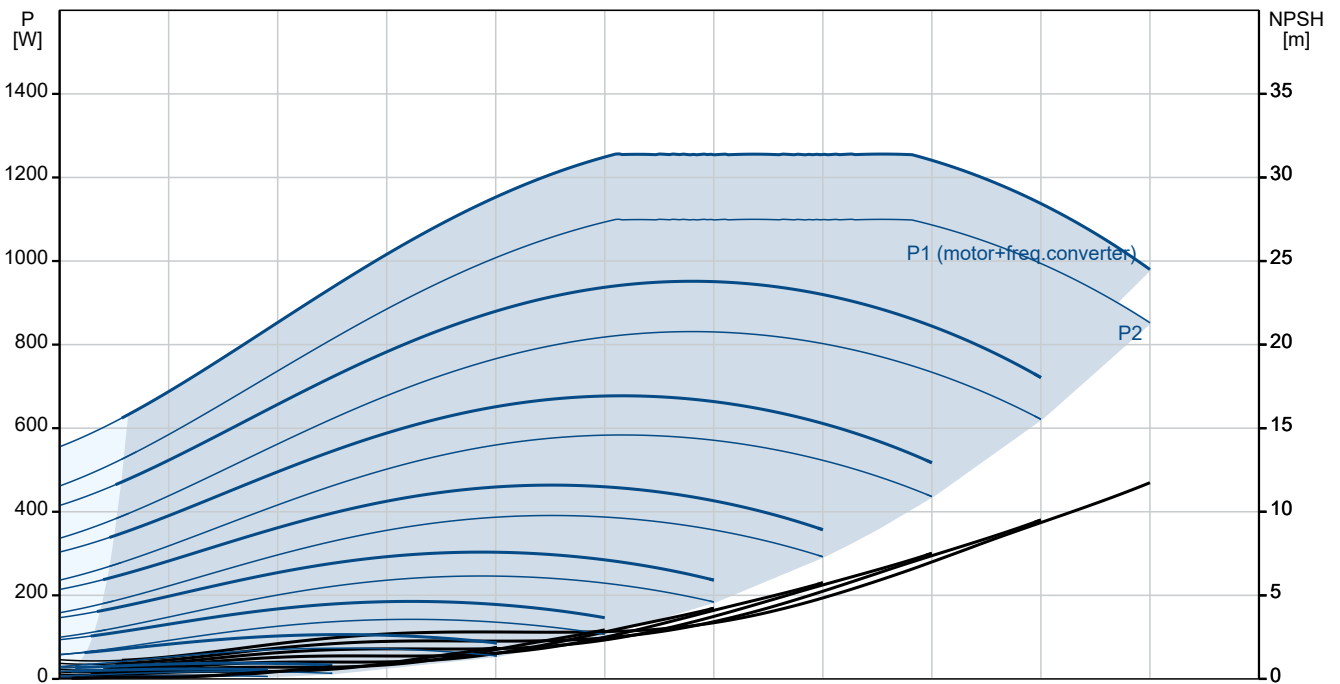
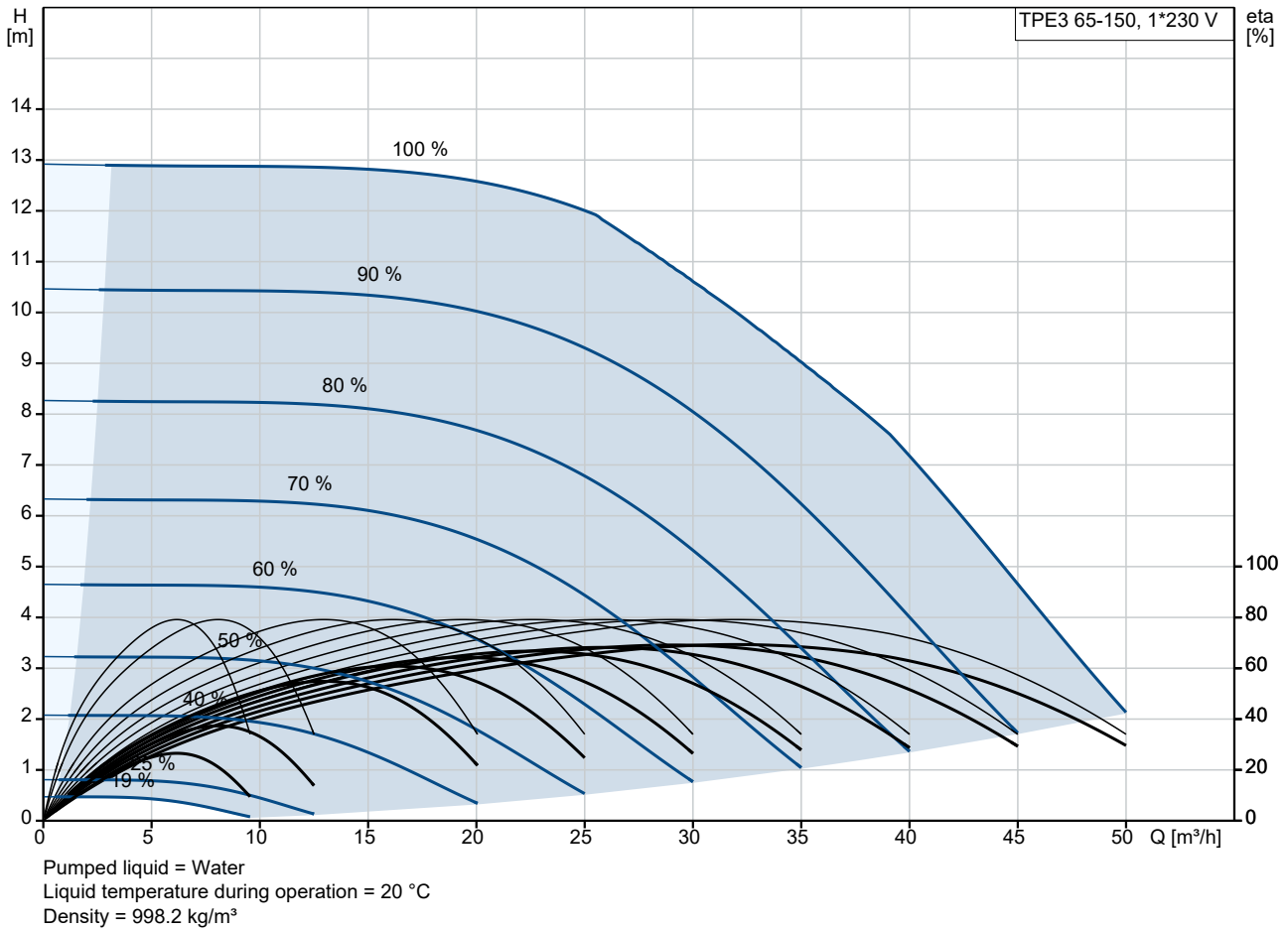

**Project:**  
**Reference Number:**

**Client:**  
**Client Number:**  
**Contact:**

Description	Value
<b>General information:</b>	
Product name:	TPE3 65-150 S-A-F-I-BQQE-GWB
Product No:	98416836
EAN number:	5711494656264
<b>Technical:</b>	
Pump speed on which pump data are based:	4000 rpm
Rated flow:	32.7 m <sup>3</sup> /h
Rated head:	9.8 m
Maximum head:	150 dm
Actual impeller diameter:	78 mm
Code for shaft seal:	BQQE
Curve tolerance:	ISO9906:2012 3B2
Pump version:	A
<b>Materials:</b>	
Pump housing:	Stainless steel
Pump housing:	EN 1.4308
Pump housing:	ASTM CF8
Impeller:	Composite
Impeller:	PES+30% GF
Material code:	I
<b>Installation:</b>	
Range of ambient temperature:	-20 .. 50 °C
Maximum operating pressure:	10 bar
Max pressure at stated temp:	10 bar / 120 °C
Type of connection:	DIN
Size of connection:	DN 65
Pressure rating for connection:	PN 6/10
Port-to-port length:	340 mm
Flange size for motor:	56C
Connect code:	F
<b>Liquid:</b>	
Pumped liquid:	Water
Liquid temperature range:	-25 .. 120 °C
Selected liquid temperature:	20 °C
Density:	998.2 kg/m <sup>3</sup>
<b>Electrical data:</b>	
Motor type:	80B
Rated power - P2:	1.1 kW
Mains frequency:	50 / 60 Hz
Rated voltage:	1 x 200-240 V
Rated current:	6.70-5.60 A
Cos phi - power factor:	0.99
Rated speed:	360-4000 rpm
IE Efficiency class:	IE5
Motor efficiency at full load:	86.9 %
Enclosure class (IEC 34-5):	IP55
Insulation class (IEC 85):	F
Built-in motor protection:	ELEC
Motor No:	99137987
<b>Controls:</b>	
Control panel:	HMI300 - Graphical
Function Module:	FM300 - Advanced
Frequency converter:	Built-in

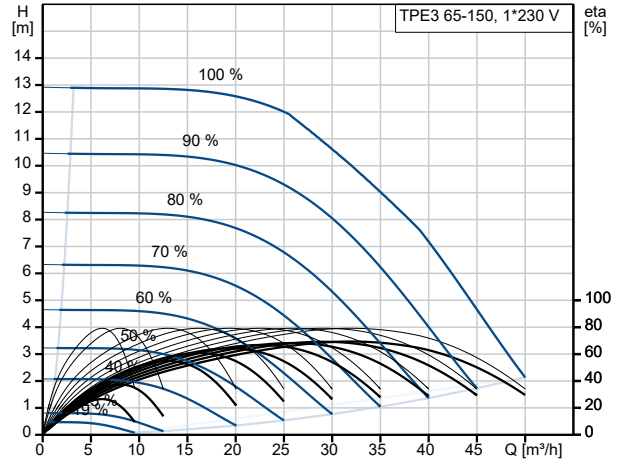

Pumped liquid = Water  
 Liquid temperature during operation = 20 °C  
 Density = 998.2 kg/m<sup>3</sup>

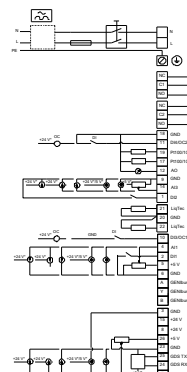
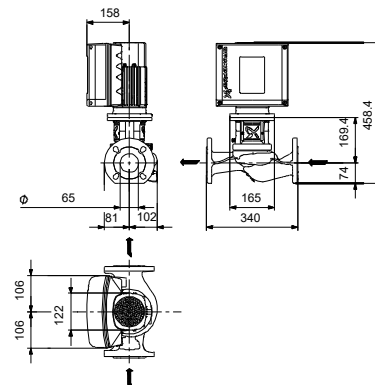
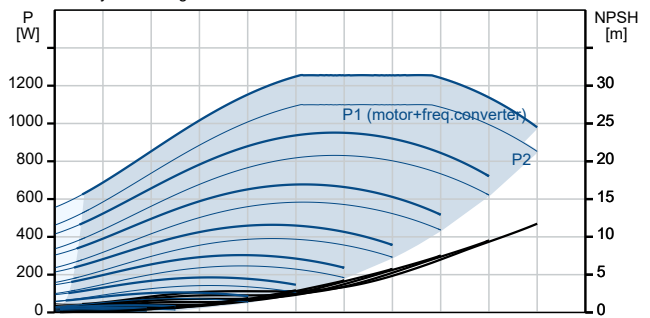



**Company name:** national pumps and boilers  
**Created by:**  
**Phone:** 01539 729395  
**Email:** info@nationlapumpsandboilers.co.uk  
**Date:** 02/01/2024

**Project:**  
**Reference Number:**

**Client:**  
**Client Number:**  
**Contact:**

Description	Value
<b>Others:</b>	
Minimum efficiency index, MEI ≥:	0.70
Net weight:	28.6 kg
Gross weight:	37.3 kg
Shipping volume:	0.164 m <sup>3</sup>
Config. file no:	98481406
Danish VVS No.:	382143150

Project:  
 Reference Number:

Client:  
 Client Number:  
 Contact:

**98416836 TPE3 65-150 S-A-F-I-BQQE-GWB**

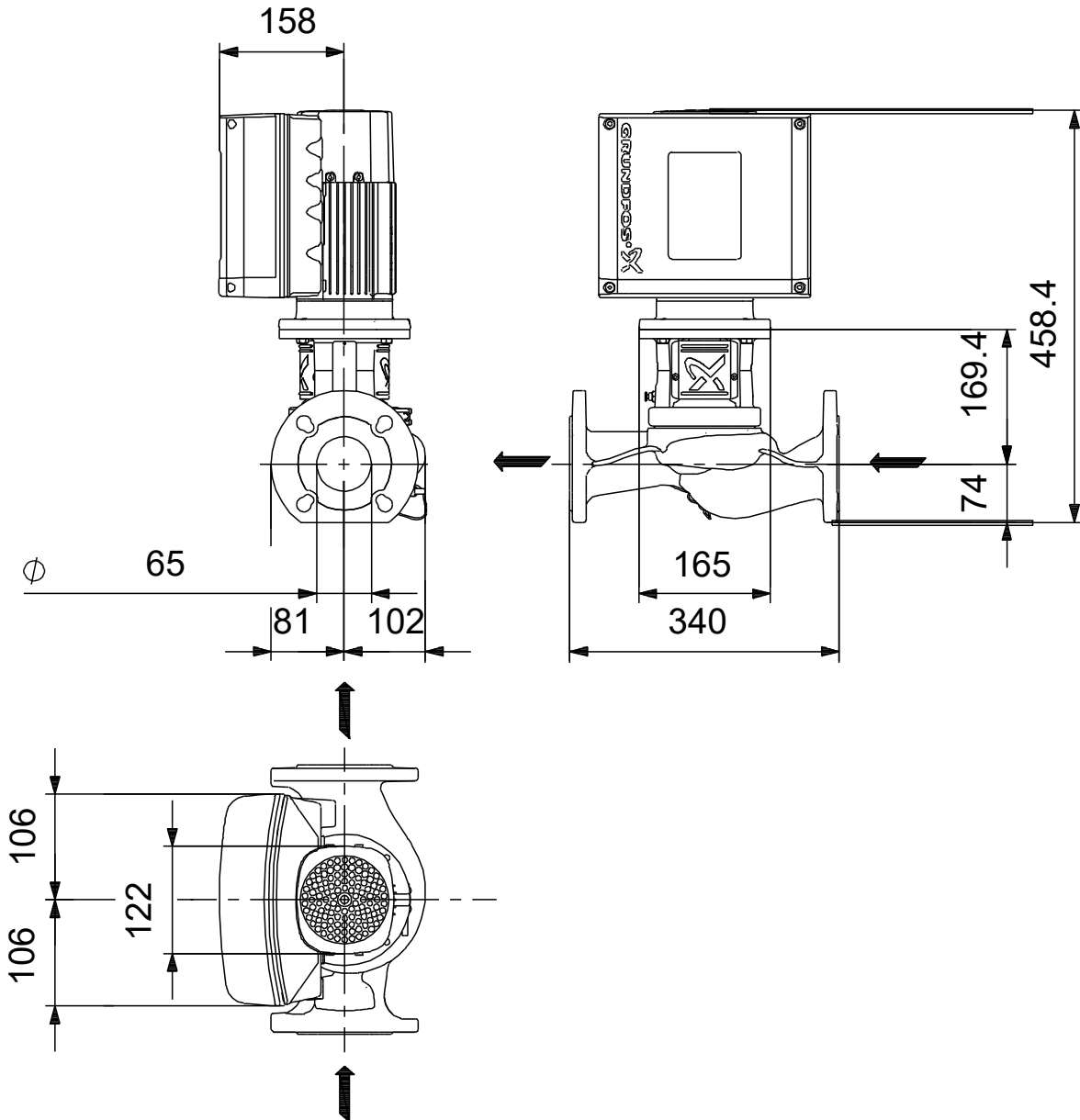

Note! All units are in [mm] unless others are stated.  
 Disclaimer: This simplified dimensional drawing does not show all details.



**Project:**  
**Reference Number:**

**Client:**  
**Client Number:**  
**Contact:**

## 98416836 TPE3 65-150 S-A-F-I-BQQE-GWB

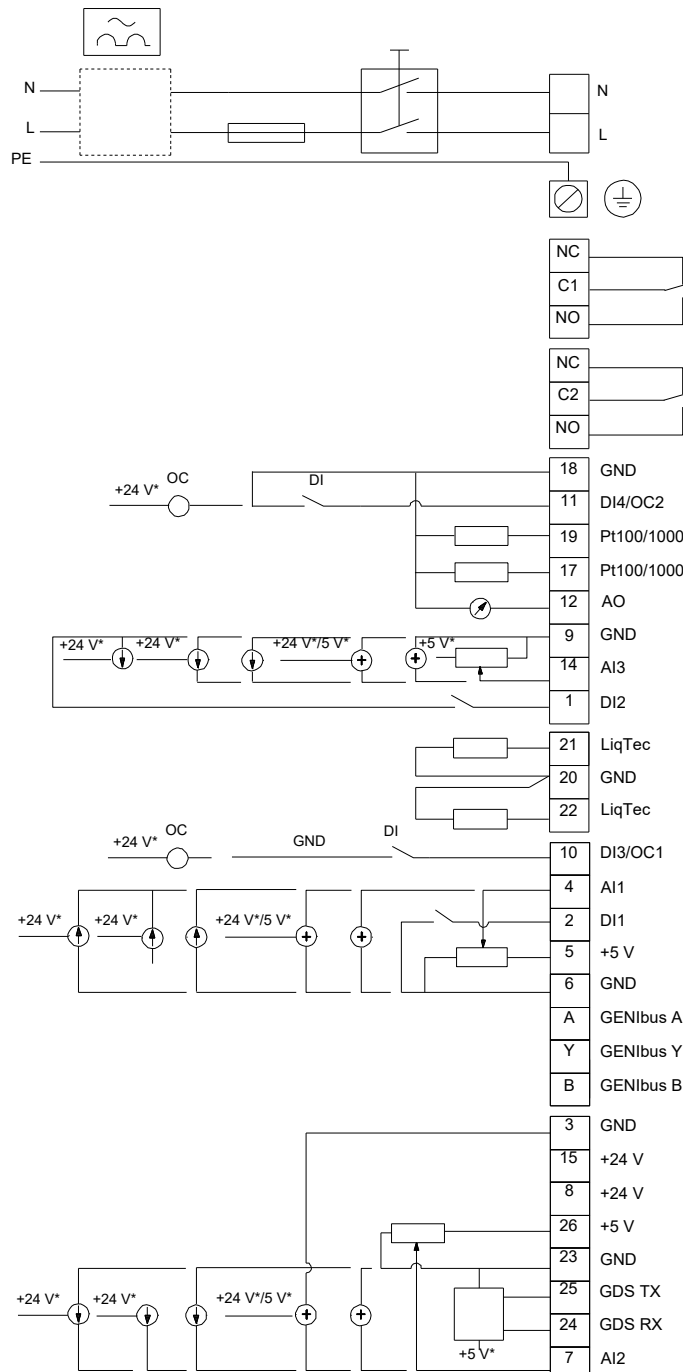

Note! All units are in [mm] unless others are stated.