

PROJECT:	UNIT TAG:	QUANTITY:
REPRESENTATIVE: _____	TYPE OF SERVICE:	DATE: _____
ENGINEER:	SUBMITTED BY:	DATE:
CONTRACTOR:	APPROVED BY:	DATE:
	ORDER NO.:	DATE:



## MAGNA1 100-100 F

The Grundfos MAGNA1 circulator pump is ideal for basic performance needs in heating and cooling applications. The pump offers basic system control and monitoring and can communicate via a fault relay and digital start/stop.

Note! Product picture may differ from actual product

Conditions of Service		Pump Data		Motor Data	
Liquid:	Water	Maximum operating pressure:	6 bar	P1 max:	31.31 .. 1413 W
Temperature:	60 °C	Liquid temperature range:	-10 .. 110 °C	Mains frequency:	50 / 60 Hz
Specific Gravity:	0.985	Maximum ambient temperature:	40 °C	Enclosure class:	X4D
		Flange standard:	DIN	Insulation class:	F
		Pipe connection:	DN 100		
		Product number:	On request		

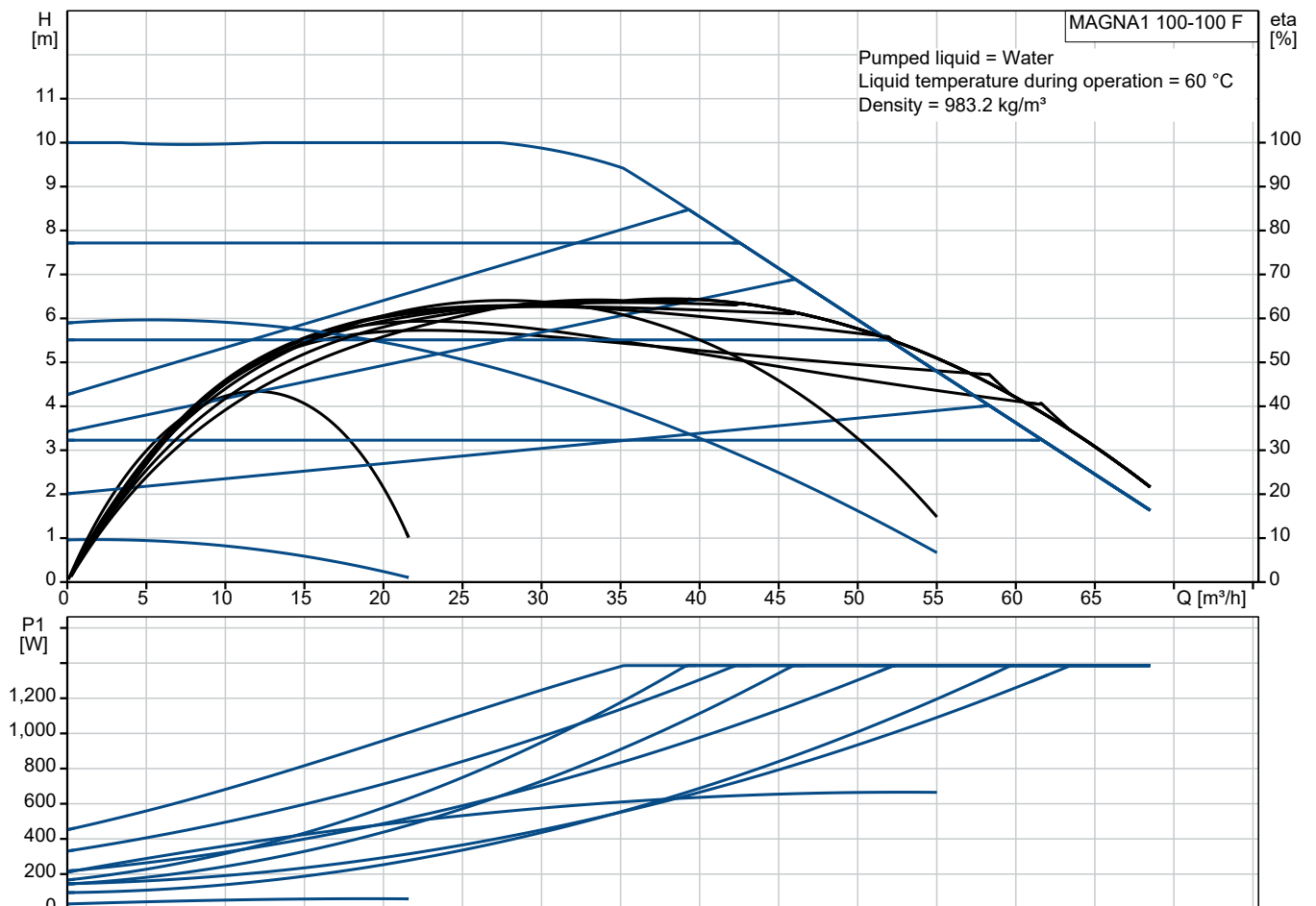

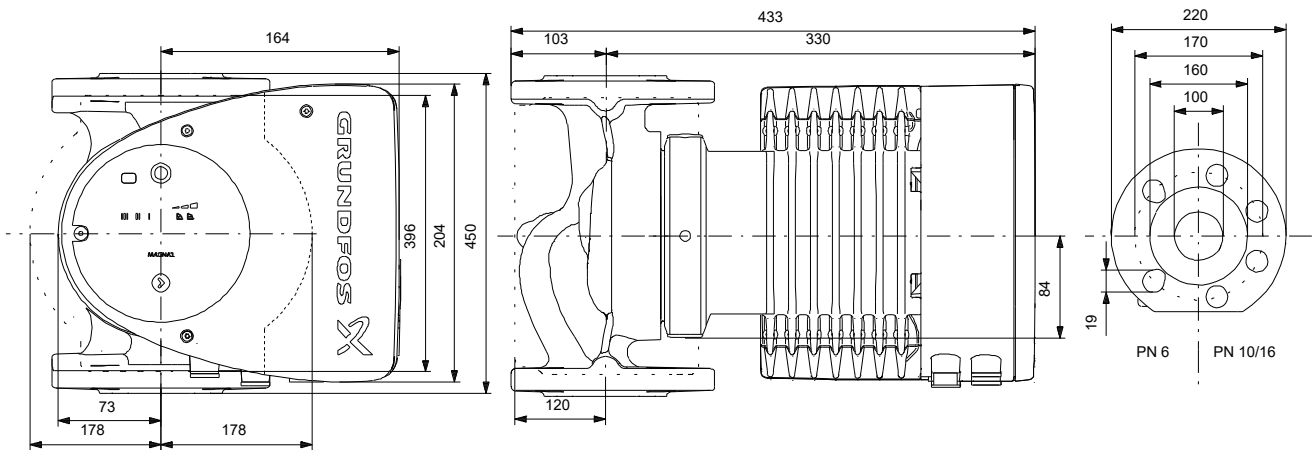

**Materials:**

- Pump housing: Cast iron
- Pump housing: EN-GJL-250
- Pump housing: ASTM A48-250B
- Impeller: PES 30%GF

Qty.	Description
------	-------------

1	MAGNA1 100-100 F
---	------------------



Note! Product picture may differ from actual product

Product No.: On request

The Grundfos MAGNA1 circulator pump is the simple option for a job well done.

With its high energy efficiency the product lives up to the EuP 2015 regulations ensuring substantial savings on electricity, and with its intuitive, user-friendly interface and maintenance-free design, MAGNA1 is the ideal circulator pump for basic performance needs in applications where basic system control and monitoring are desired.

With this range of circulator pumps, everything from setup to basic control and monitoring are made easy. The pump is maintenance-free due to the canned-rotor type design.

MAGNA1 offers the possibility of monitoring the pump via the fault relay output. The digital start/stop input remotely controls the pump.

The pump communicates wirelessly with the Grundfos GO Remote app.

MAGNA1 can work as main pump in both heating and cooling applications, including:

- Mixing loops
- Heating surfaces
- Air-conditioning surfaces
- Ground-source heat pump systems
- Smaller chiller applications.

MAGNA1 is a single-phase pump and characterised by having the controller and operating panel integrated in the control box.

The pump housing is available in both cast-iron and stainless-steel versions.

The composite rotor can is carbon-fibre reinforced, the bearing plate and rotor cladding are made of stainless steel and the stator housing is made of aluminium.

The power electronics are air-cooled.

The pump incorporates a 4-pole synchronous, permanent-magnet motor (PM motor). This motor type is characterised by higher efficiency than a conventional asynchronous squirrel-cage motor. The pump speed is controlled by an integrated frequency converter.

## On request MAGNA1 100-100 F

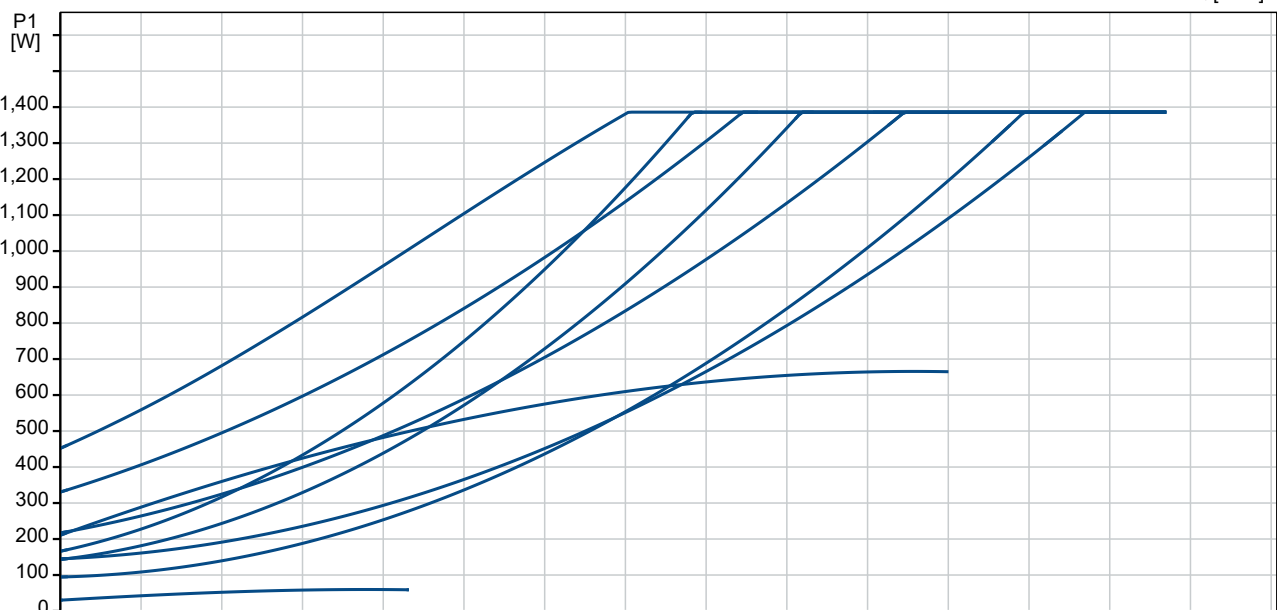
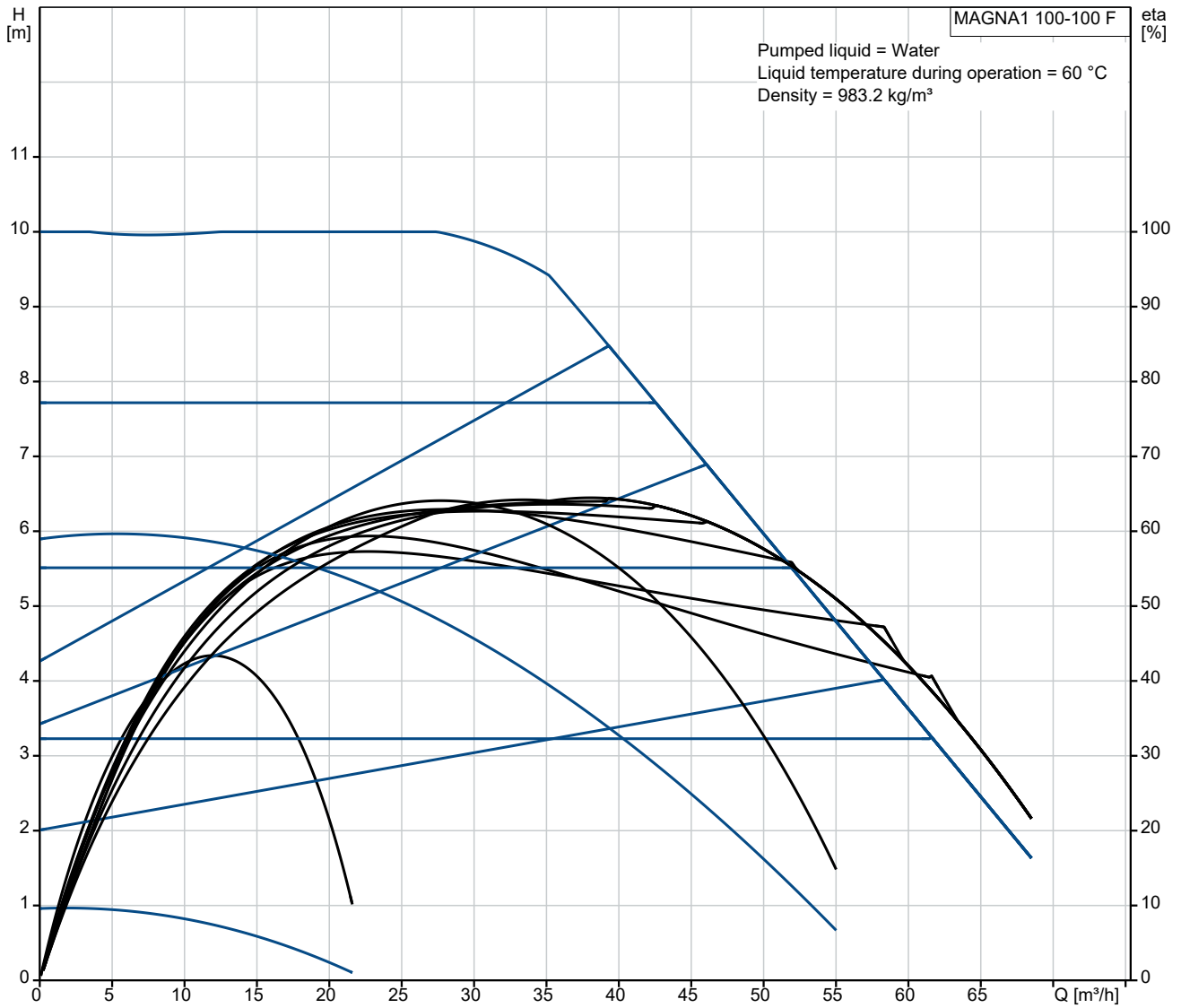

Description	Value
<b>General information:</b>	
Product name:	MAGNA1 100-100 F
Product No:	On request
EAN number:	On request
<b>Technical:</b>	
Head max:	100 dm
TF class:	110
Approvals:	CE,VDE,EAC,MOROCCO,UKCA,TSERCM,UkrSEPRO
Model:	C
<b>Materials:</b>	
Pump housing:	Cast iron
Pump housing:	EN-GJL-250
Pump housing:	ASTM A48-250B
Impeller:	PES 30%GF
<b>Installation:</b>	
Range of ambient temperature:	0 .. 40 °C
Maximum operating pressure:	6 bar
Flange standard:	DIN
Pipe connection:	DN 100
Pressure rating:	PN 6
Port-to-port length:	450 mm
<b>Liquid:</b>	
Pumped liquid:	Water
Liquid temperature range:	-10 .. 110 °C
Selected liquid temperature:	60 °C
Density:	983.2 kg/m <sup>3</sup>
<b>Electrical data:</b>	
Power input - P1:	31.31 .. 1413 W
Mains frequency:	50 / 60 Hz
Rated voltage [V]:	1 x 230 V
Maximum current consumption:	0.32 .. 6.23 A
Enclosure class (IEC 34-5):	X4D
Insulation class (IEC 85):	F
<b>Others:</b>	
Energy (EEL):	0.19
Environmental approvals:	CN ROHS, WEEE
Net weight:	34.4 kg
Gross weight:	37.7 kg
Shipping volume:	0.097 m <sup>3</sup>
Country of origin:	DE
Custom tariff no.:	84139100

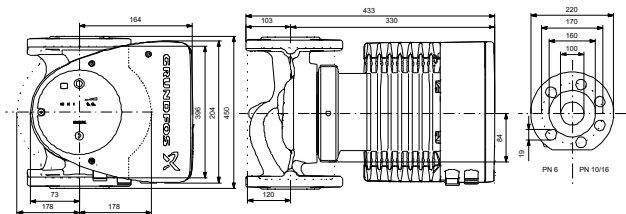
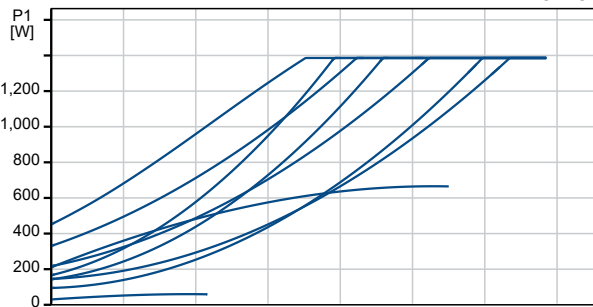
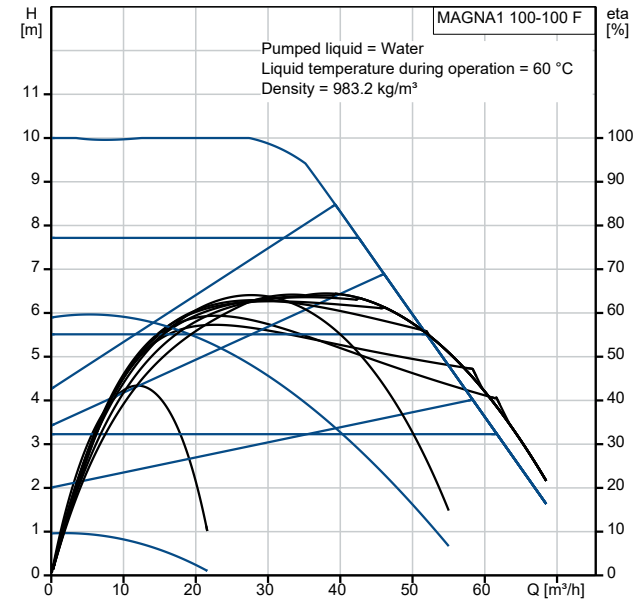

Example of mains-connected motor with mains switch, backup fuse and additional protection

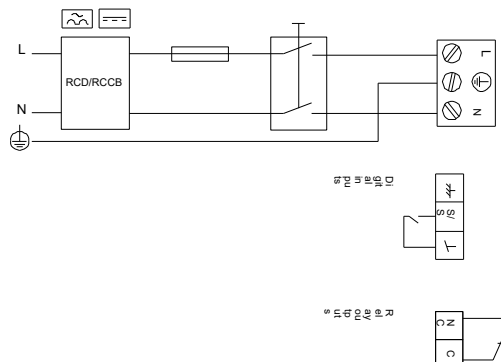

## On request MAGNA1 100-100 F

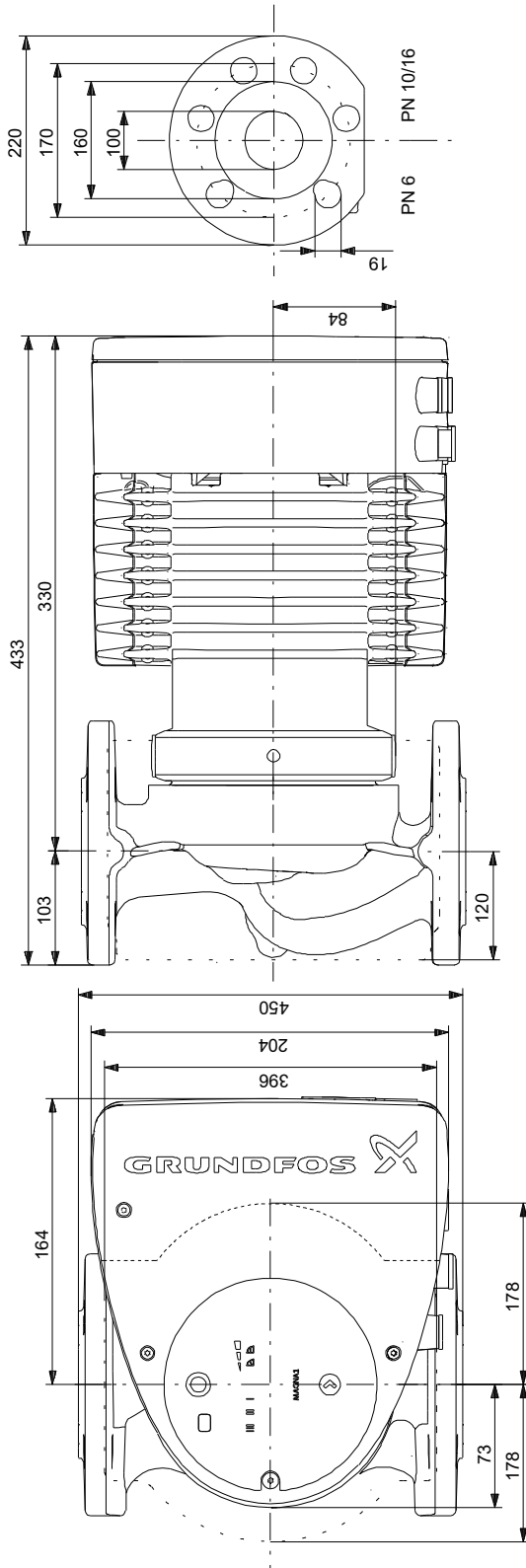

Note! All units are in [mm] unless others are stated.  
Disclaimer: This simplified dimensional drawing does not show all details.

## On request MAGNA1 100-100 F

Example of mains-connected motor with mains switch, backup fuse and additional protection

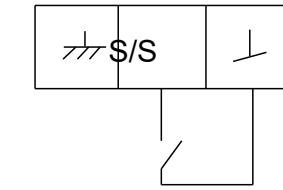
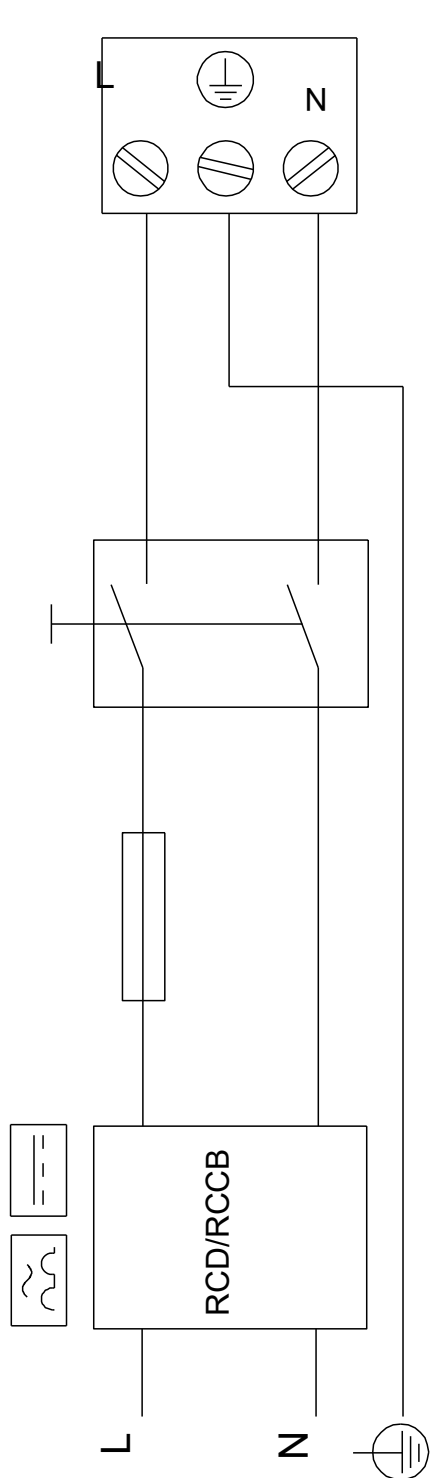

Digital inputs

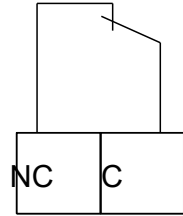

Relay outputs

Note! All units are in [mm] unless others are stated.





( TM054005 for Magna1 750-1600W)

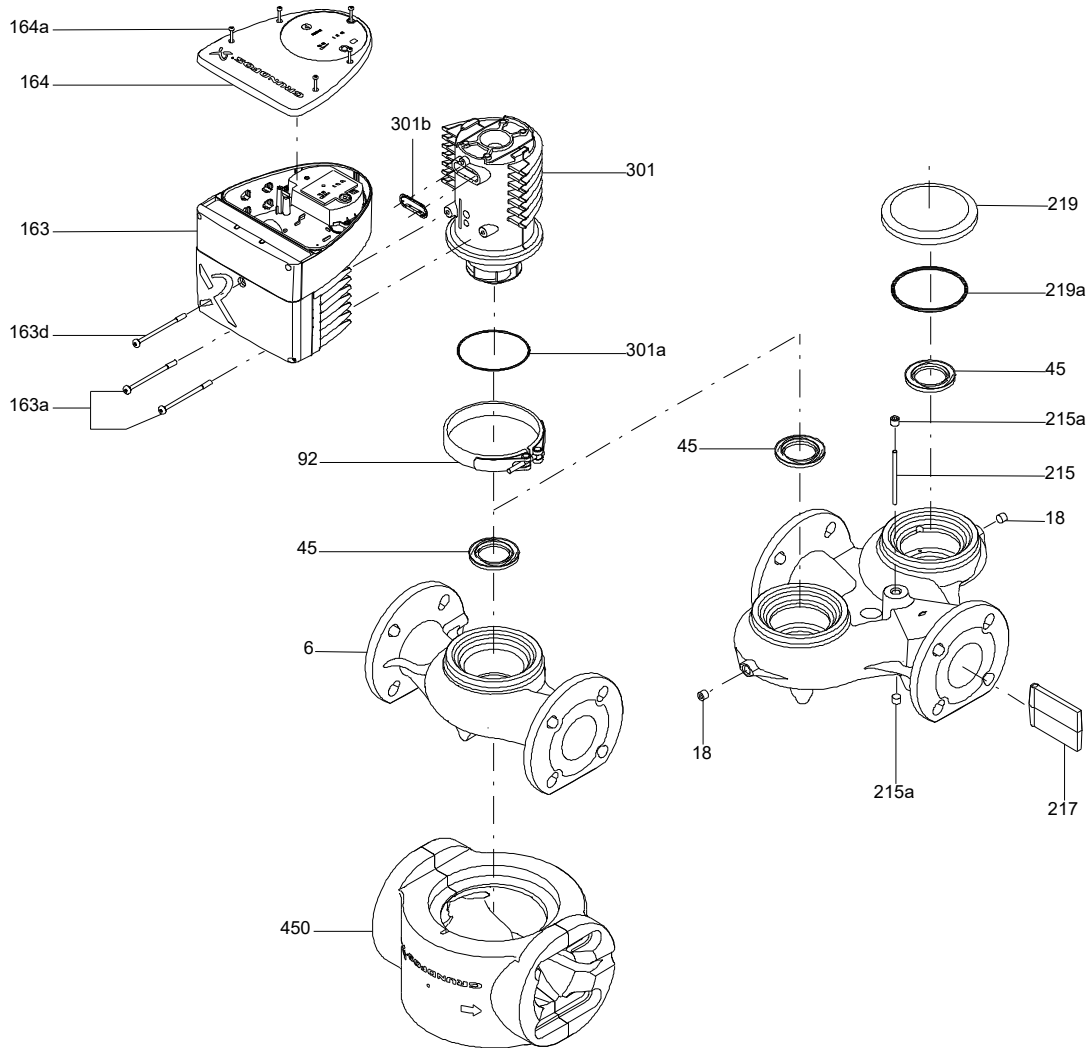

( TM069997 Magna1 ME/LA model C )

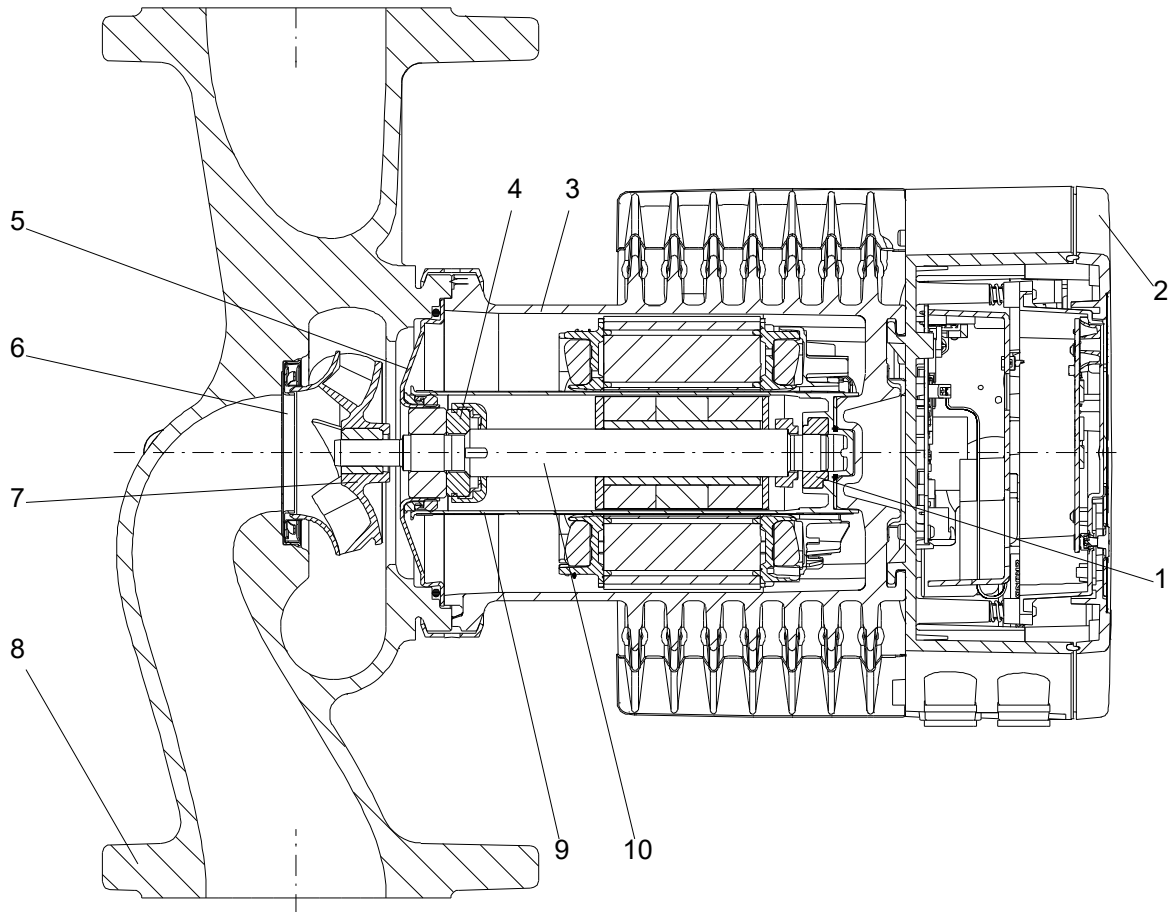

**Spare parts MAGNA1 100-100 F, Product No. On request  
Produced After 1731 (production year and week number)**

Pos	Description	Annotation	Classification Data	Part no.	Qty.	Unit
-	Kit, Control box configured			99426934	1	pcs
-	Kit,control box non-configured			99280446	1	
-	Control box cpl.					
-	Control box					
159c	Pan washer head screw					
164a	Screw DELTA PT					
164	Cover					
163	Control box					
163d	Pan head screw					
163a	Pan head screw					
301b	Protector					
	GSC				1	
-	Kit, Cover			99280465	1	pcs
164a	Screw DELTA PT				5	
164	Cover				1	
-	Kit, Pump head			98861442	1	pcs
-	Mounting kit				1	
163d	Pan head screw					
163a	Pan head screw					
92	Clamp cpl.				1	
301b	Protector				1	
301	Pump head				1	
-	Spare, Clamp			98148759	1	pcs
92	Clamp cpl.				1	
-	Spare, O-ring			98148761	1	pcs
301a	O-ring				1	
-	Pump housing cpl.			98660060	1	pcs
45	Neck ring cpl.			99244194	1	
450	Insulation			98159362	1	pcs