

PROJECT:	UNIT TAG:	QUANTITY:
REPRESENTATIVE: _____	TYPE OF SERVICE:	DATE: _____
ENGINEER:	SUBMITTED BY:	DATE:
CONTRACTOR:	APPROVED BY:	DATE:
	ORDER NO.:	DATE:



## MAGNA1 100-60 F

The Grundfos MAGNA1 circulator pump is ideal for basic performance needs in heating and cooling applications. The pump offers basic system control and monitoring and can communicate via a fault relay and digital start/stop.

Note! Product picture may differ from actual product

Conditions of Service		Pump Data		Motor Data	
Flow:	20.42 m <sup>3</sup> /h	Maximum operating pressure:	6 bar	P1 max:	25.6 .. 708 W
Head:	5.877 m	Liquid temperature range:	-10 .. 110 °C	Mains frequency:	50 / 60 Hz
Efficiency:	60.8 %	Maximum ambient temperature:	40 °C	Enclosure class:	X4D
Liquid:	Water	Flange standard:	DIN	Insulation class:	F
Temperature:	60 °C	Pipe connection:	DN 100		
Specific Gravity:	0.985	Product number:	On request		

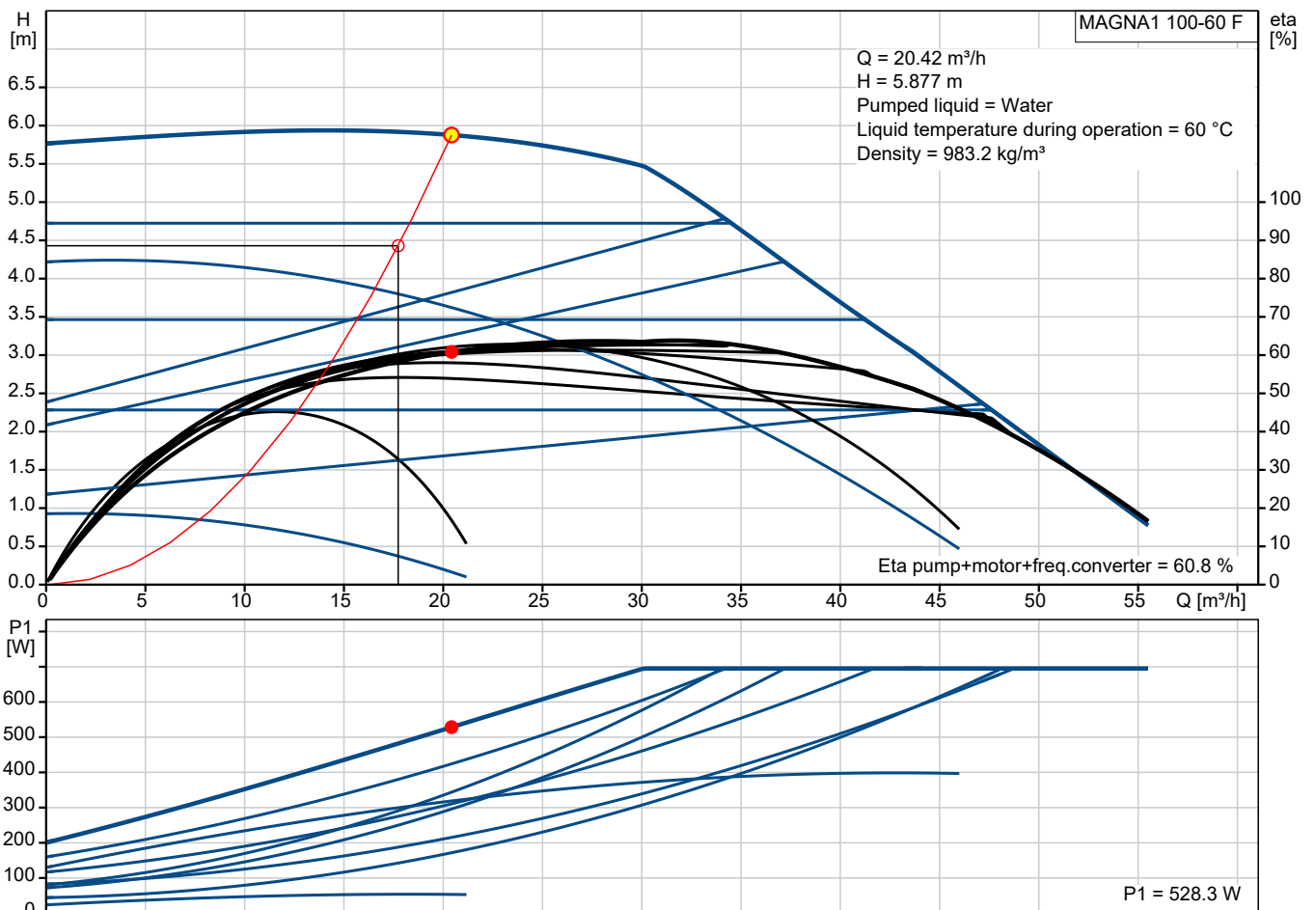

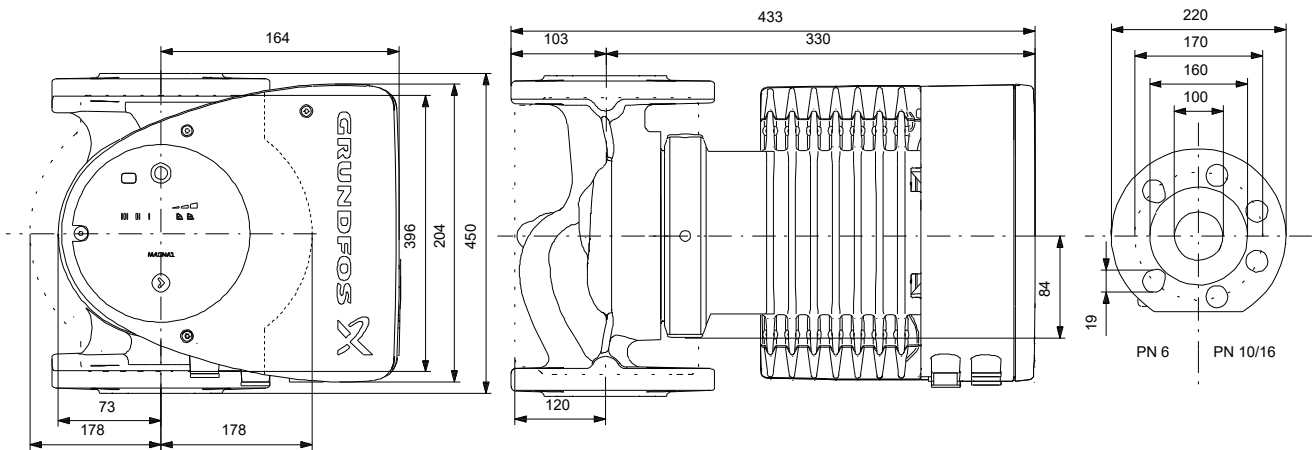

**Materials:**

- Pump housing: Cast iron
- Pump housing: EN-GJL-250
- Pump housing: ASTM A48-250B
- Impeller: PES 30%GF

Qty.	Description
------	-------------

1	MAGNA1 100-60 F
---	-----------------



Note! Product picture may differ from actual product

Product No.: On request

The Grundfos MAGNA1 circulator pump is the simple option for a job well done.

With its high energy efficiency the product lives up to the EuP 2015 regulations ensuring substantial savings on electricity, and with its intuitive, user-friendly interface and maintenance-free design, MAGNA1 is the ideal circulator pump for basic performance needs in applications where basic system control and monitoring are desired.

With this range of circulator pumps, everything from setup to basic control and monitoring are made easy. The pump is maintenance-free due to the canned-rotor type design.

MAGNA1 offers the possibility of monitoring the pump via the fault relay output. The digital start/stop input remotely controls the pump.

The pump communicates wirelessly with the Grundfos GO Remote app.

MAGNA1 can work as main pump in both heating and cooling applications, including:

- Mixing loops
- Heating surfaces
- Air-conditioning surfaces
- Ground-source heat pump systems
- Smaller chiller applications.

MAGNA1 is a single-phase pump and characterised by having the controller and operating panel integrated in the control box.

The pump housing is available in both cast-iron and stainless-steel versions.

The composite rotor can is carbon-fibre reinforced, the bearing plate and rotor cladding are made of stainless steel and the stator housing is made of aluminium.

The power electronics are air-cooled.

The pump incorporates a 4-pole synchronous, permanent-magnet motor (PM motor). This motor type is characterised by higher efficiency than a conventional asynchronous squirrel-cage motor. The pump speed is controlled by an integrated frequency converter.

## On request MAGNA1 100-60 F

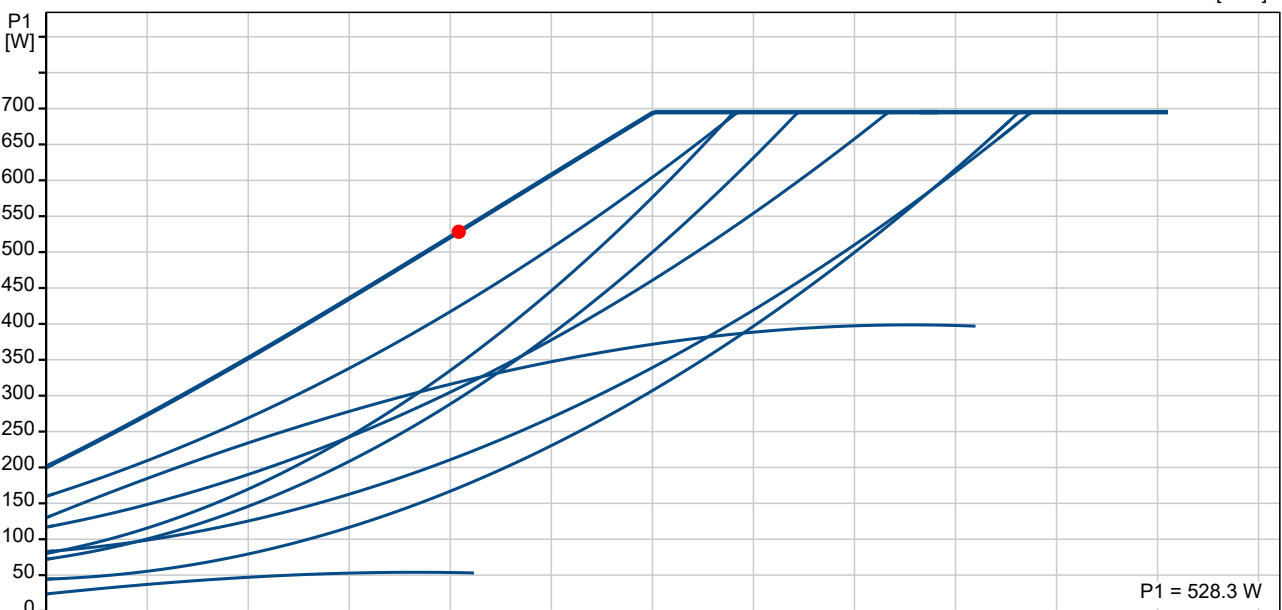
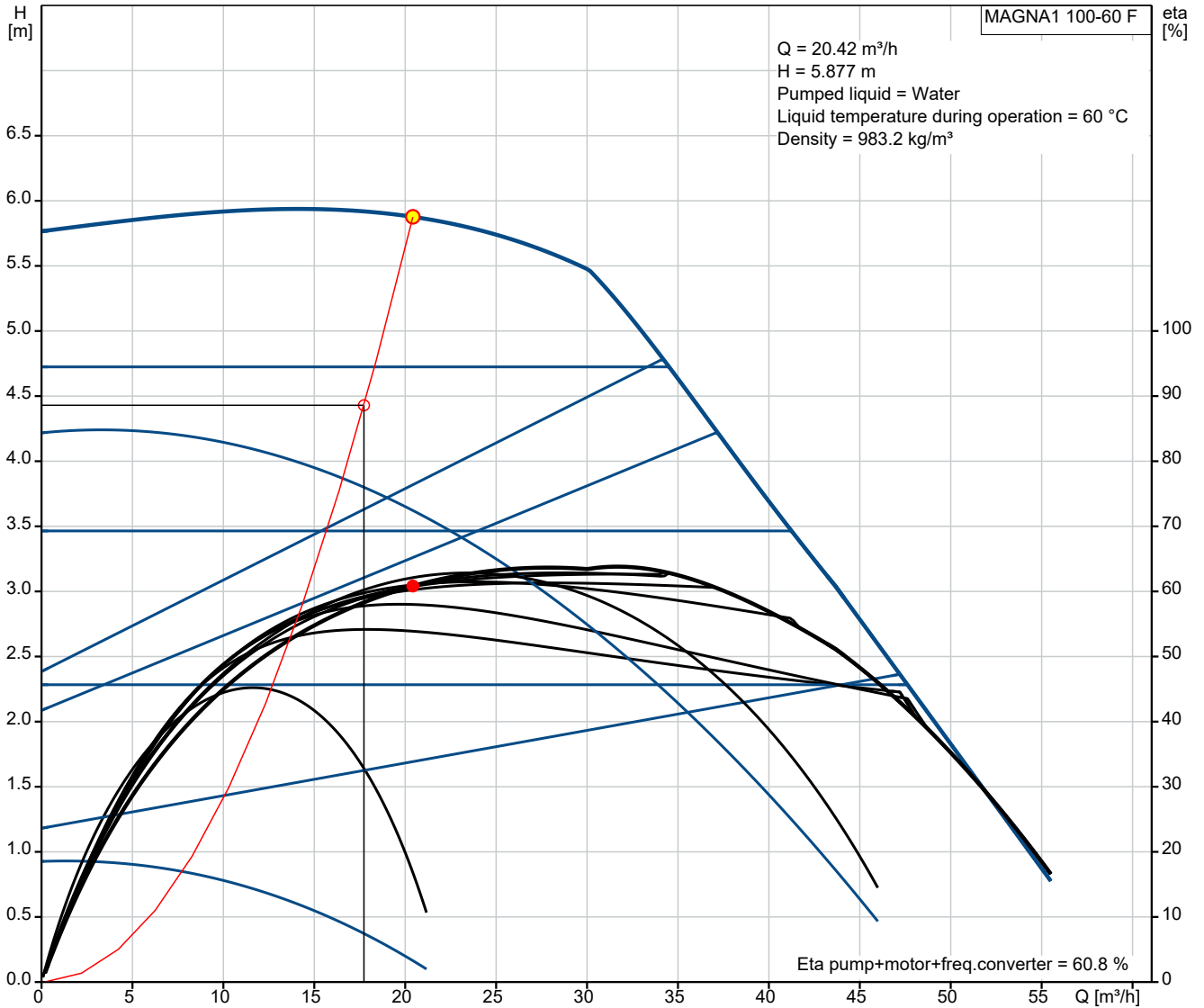

Description	Value
<b>General information:</b>	
Product name:	MAGNA1 100-60 F
Product No:	On request
EAN number:	On request
<b>Technical:</b>	
Actual calculated flow:	20.42 m <sup>3</sup> /h
Resulting head of the pump:	5.877 m
Head max:	60 dm
TF class:	110
Approvals:	CE, VDE, EAC, MOROCCO, UKCA, TSERCM, UkrSEPRO
Model:	C
<b>Materials:</b>	
Pump housing:	Cast iron
Pump housing:	EN-GJL-250
Pump housing:	ASTM A48-250B
Impeller:	PES 30%GF
<b>Installation:</b>	
Range of ambient temperature:	0 .. 40 °C
Maximum operating pressure:	6 bar
Flange standard:	DIN
Pipe connection:	DN 100
Pressure rating:	PN 6
Port-to-port length:	450 mm
<b>Liquid:</b>	
Pumped liquid:	Water
Liquid temperature range:	-10 .. 110 °C
Selected liquid temperature:	60 °C
Density:	983.2 kg/m <sup>3</sup>
<b>Electrical data:</b>	
Power input - P1:	25.6 .. 708 W
Mains frequency:	50 / 60 Hz
Rated voltage [V]:	1 x 230 V
Maximum current consumption:	0.27 .. 3.13 A
Enclosure class (IEC 34-5):	X4D
Insulation class (IEC 85):	F
<b>Others:</b>	
Energy (EEL):	0.19
Environmental approvals:	CN ROHS, WEEE
Net weight:	33.4 kg
Gross weight:	36.7 kg
Shipping volume:	0.097 m <sup>3</sup>
Country of origin:	DE
Custom tariff no.:	84137030

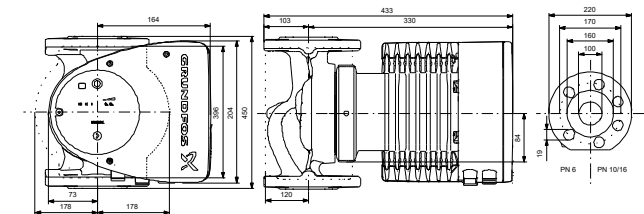
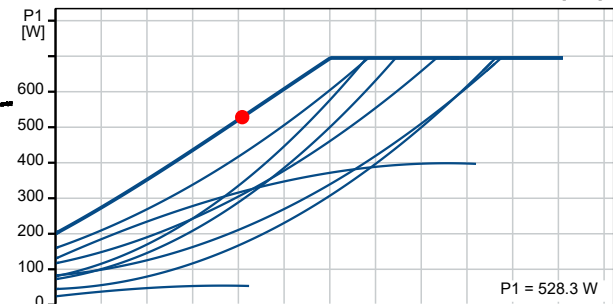
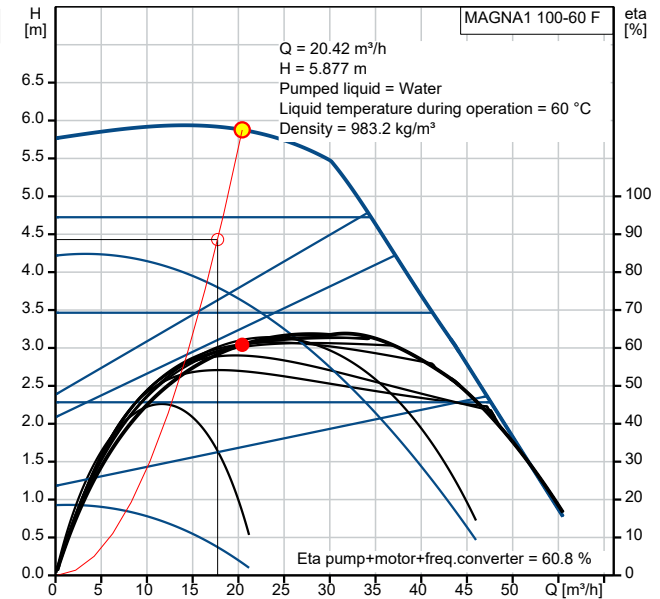

Example of mains-connected motor with mains switch, backup fuse and additional protection

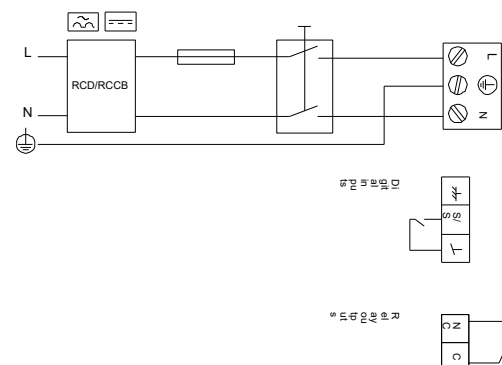

## On request MAGNA1 100-60 F

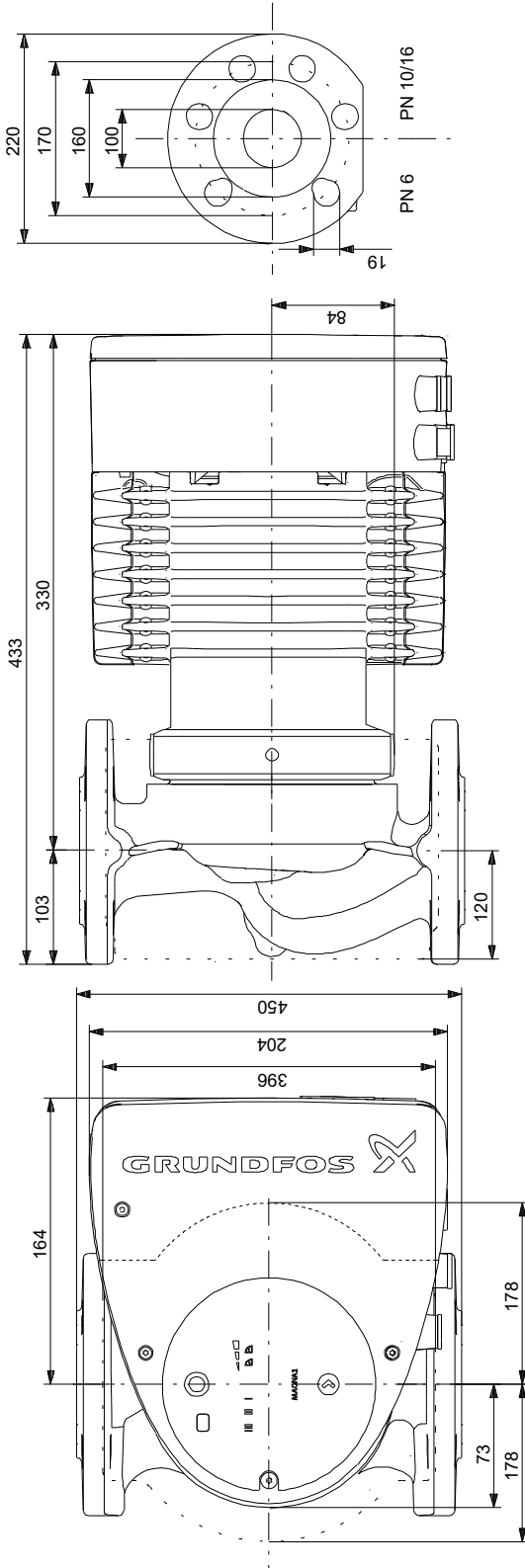

Note! All units are in [mm] unless others are stated.  
Disclaimer: This simplified dimensional drawing does not show all details.

## On request MAGNA1 100-60 F

Example of mains-connected motor with mains switch, backup fuse and additional protection

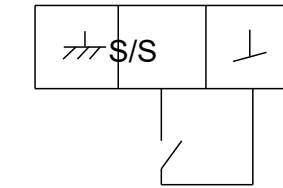
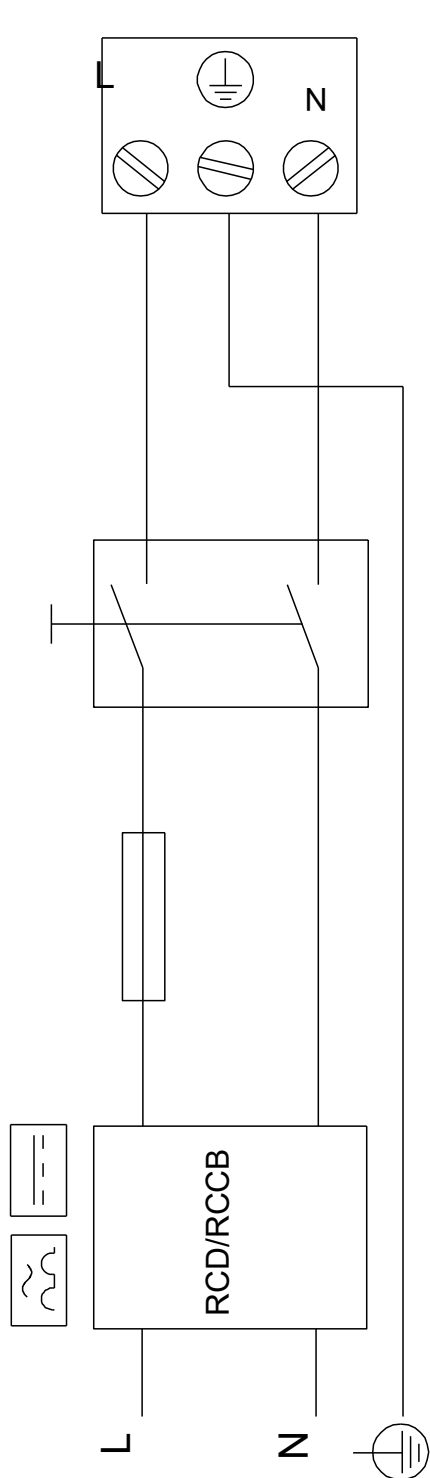

Digital inputs

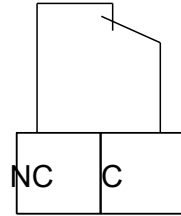

Relay outputs

Note! All units are in [mm] unless others are stated.



Company name:

Created by:

Phone:

Date:

25/09/2022

**Order Data:**

Position	Your pos.	Product name	Amount	Product No	Total
		MAGNA1 100-60 F	1	On request	Price on request



( TM054005 for Magna1 750-1600W)

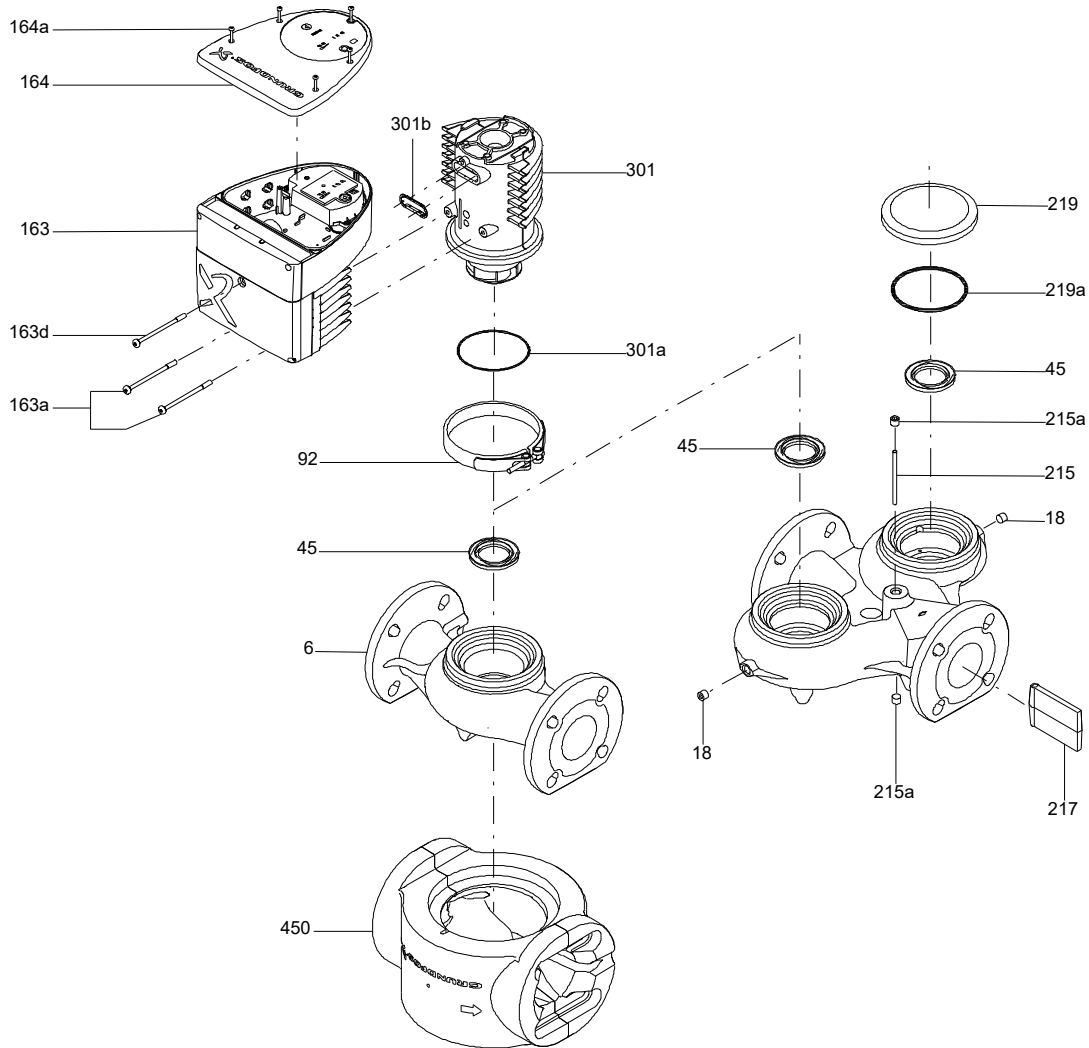

( TM069997 Magna1 ME/LA model C )

