

Qty. Description

1 TP 25-50/2 A-O-A-BQQE-AW1



Note! Product picture may differ from actual product

 Product No.: [98346587](#)

Single-stage, close-coupled, volute pump with in-line suction and discharge ports of identical diameter. The pump is of the top-pull-out design, i.e. the power head (motor, pump head and impeller) can be removed for maintenance or service while the pump housing remains in the pipework.

The pump is fitted with an unbalanced rubber bellows seal. The shaft seal is according to EN 12756. The pump is fitted with a fan-cooled asynchronous motor.

Controls:

Frequency converter: None

Liquid:

Pumped liquid: Water

Liquid temperature range: -25 .. 120 °C

Selected liquid temperature: 20 °C

 Density: 998.2 kg/m³
Technical:

Pump speed on which pump data are based: 2800 rpm

 Rated flow: 3.72 m³/h

Rated head: 2.7 m

Actual impeller diameter: 68 mm

Code for shaft seal: BQQE

Curve tolerance: ISO9906:2012 3B2

Materials:

 Pump housing: Cast iron
 EN-GJL-150
 ASTM class 25

 Impeller: Composite
 PES+30% GF

Installation:

Range of ambient temperature: -30 .. 40 °C

Maximum operating pressure: 10 bar

Max pressure at stated temp: 10 bar / 120 °C

Type of connection: G

Size of connection: DN 25

Pressure rating for connection: PN 10

Port-to-port length: 180 mm

Flange size for motor: FT75

Electrical data:

Motor type: 71A

Rated power - P2: 0.12 kW

Mains frequency: 50 Hz



Company name:

Created by:

Phone:

Date:

28/12/2023

Qty.	Description
1	<p>Rated voltage: 1 x 220-230 V Rated current: 0.93-0.93 A Starting current: 690-720 % Cos phi - power factor: 0.95-0.92 Rated speed: 2910-2920 rpm IE Efficiency class: IE2 Motor efficiency at full load: 60.0-60.0 % Motor efficiency at 3/4 load: 61.0-58.8 % Motor efficiency at 1/2 load: 49.9-48.2 % Number of poles: 2 Enclosure class (IEC 34-5): 55 Dust/Jetting Insulation class (IEC 85): F Motor No: 92613975</p> <p>Others: Net weight: 9.4 kg Gross weight: 11.4 kg Shipping volume: 0.041 m³ Danish VVS No.: 381800050 Country of origin: HU Custom tariff no.: 84137051</p>

98346587 TP 25-50/2 A-O-A-BQQE-AW1 50 Hz

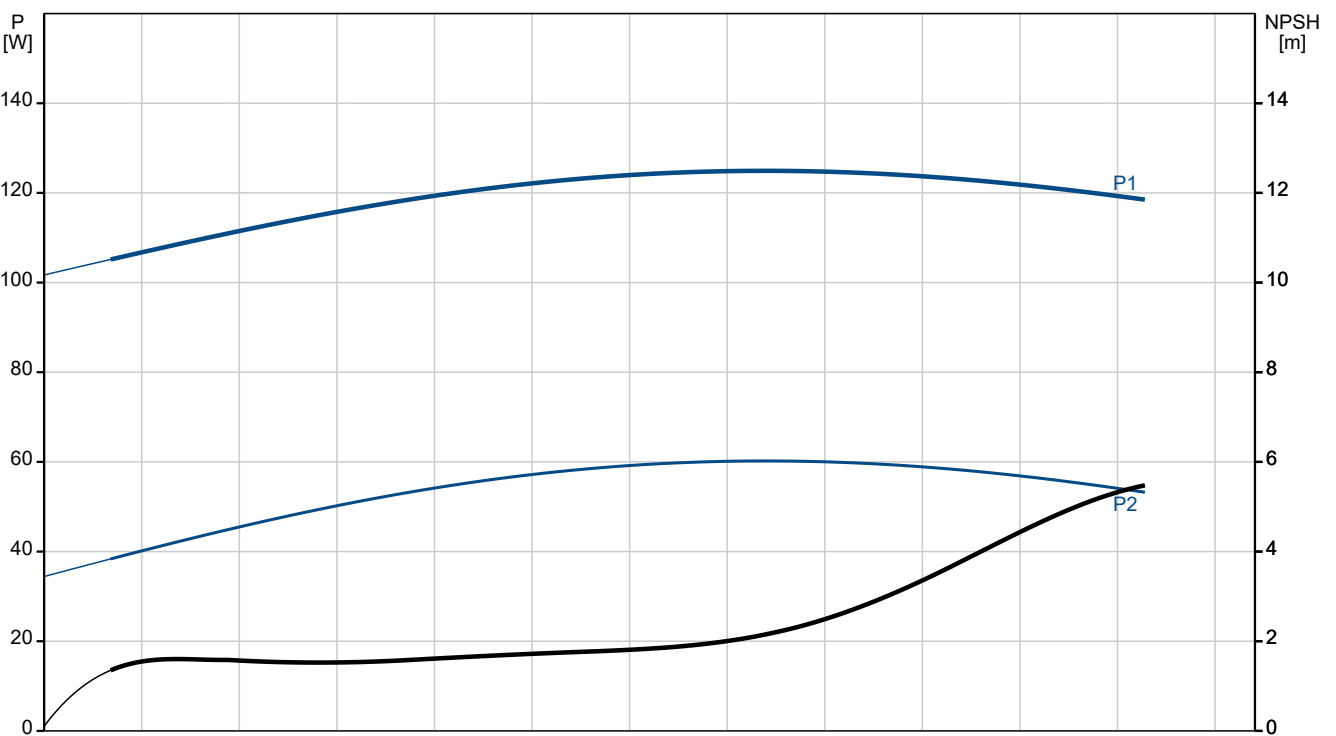
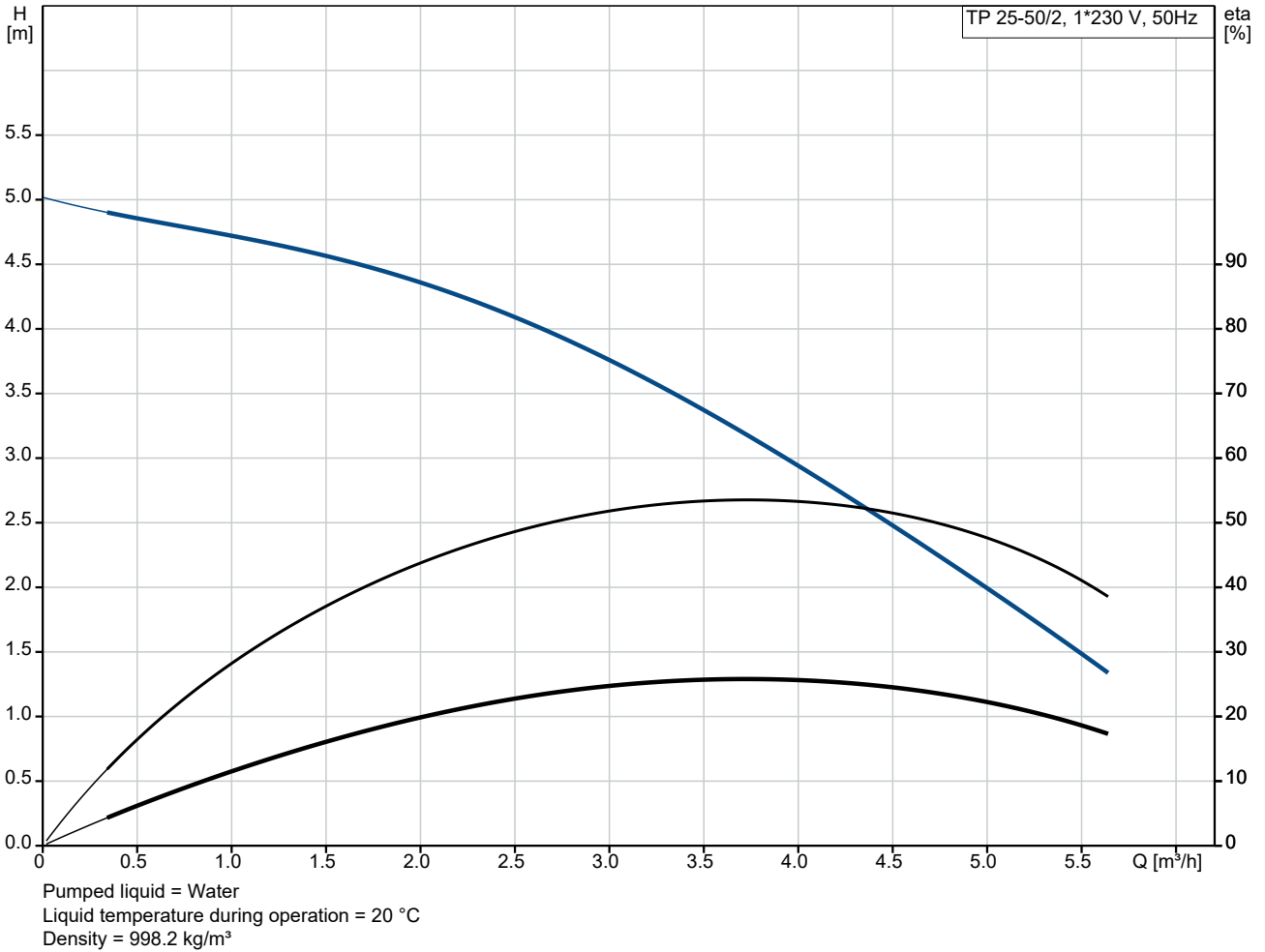

98346587 TP 25-50/2 A-O-A-BQQE-AW1 50 Hz

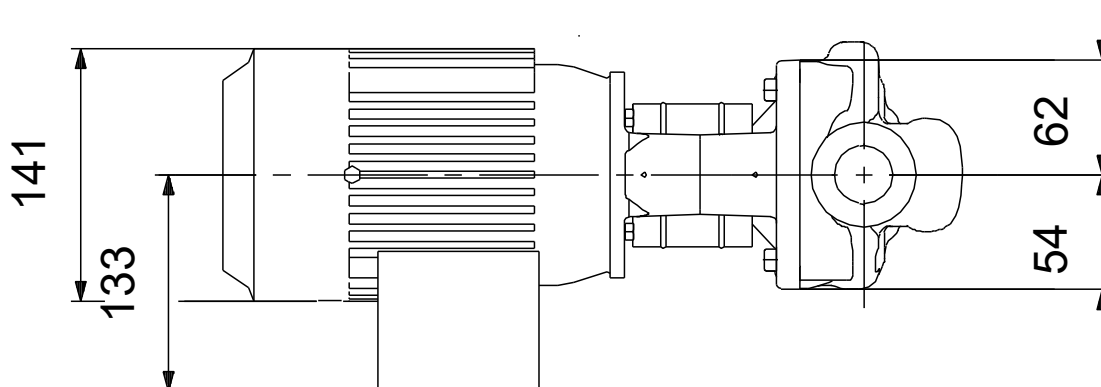
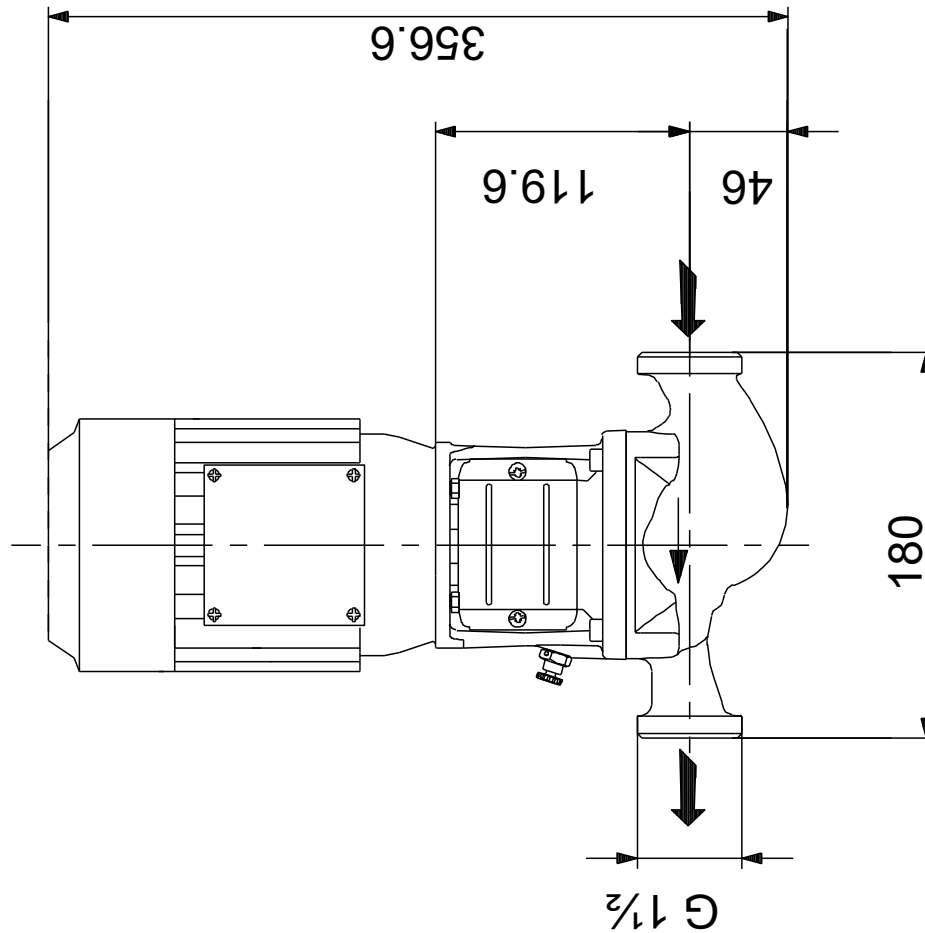

Note! All units are in [mm] unless others are stated.
Disclaimer: This simplified dimensional drawing does not show all details.