

Qty. Description

1 TP 100-480/2 A-F-A-BQQE-RW1



Note! Product picture may differ from actual product

Product No.: [96109196](#)

Single-stage, close-coupled, volute pump with in-line suction and discharge ports of identical diameter. The pump is of the top-pull-out design, i.e. the power head (motor, pump head and impeller) can be removed for maintenance or service while the pump housing remains in the pipework.

The pump is fitted with an unbalanced rubber bellows seal. The shaft seal is according to EN 12756. Pipework connection is via PN 16 DIN flanges (EN 1092-2 and ISO 7005-2).

The pump is fitted with a fan-cooled asynchronous motor.

Controls:

Frequency converter: None

Liquid:

Pumped liquid: Water
 Liquid temperature range: -25 .. 120 °C
 Selected liquid temperature: 20 °C
 Density: 998.2 kg/m³

Technical:

Pump speed on which pump data are based: 2950 rpm
 Rated flow: 156 m³/h
 Rated head: 49.4 m
 Actual impeller diameter: 200 mm
 Code for shaft seal: BQQE
 Curve tolerance: ISO9906:2012 3B

Materials:

Pump housing: Cast iron
 EN-GJL-250
 ASTM class 35
 Impeller: Cast iron
 EN-GJL-200
 ASTM class 30

Installation:

Range of ambient temperature: -20 .. 55 °C
 Maximum operating pressure: 16 bar
 Max pressure at stated temp: 16 bar / 120 °C
 Type of connection: DIN
 Size of connection: DN 100
 Pressure rating for connection: PN 16
 Port-to-port length: 550 mm
 Flange size for motor: FF350

Electrical data:

Motor type: SIEMENS

Qty.	Description
------	-------------

1	Rated power - P2: 30 kW Mains frequency: 50 Hz Rated voltage: 3 x 380-420D/660-725Y V Rated current: 53/31 A Starting current: 700-700 % Cos phi - power factor: 0.87 Rated speed: 2955 rpm IE efficiency: IE3 93,3% IE Efficiency class: IE3 Motor efficiency at full load: 93.3-93.3 % Motor efficiency at 3/4 load: 93.5-93.5 % Motor efficiency at 1/2 load: 92.9-92.9 % Number of poles: 2 Enclosure class (IEC 34-5): IP55 Insulation class (IEC 85): F Motor No: 99032179 Others: Minimum efficiency index, MEI ≥: 0.65 Net weight: 339 kg Gross weight: 394 kg Shipping volume: 0.771 m ³ Danish VVS No.: 381706480 Finnish LVI No.: 4616131 Country of origin: HU Custom tariff no.: 84137051
---	---

96109196 TP 100-480/2 A-F-A-BQQE-RW1 50 Hz

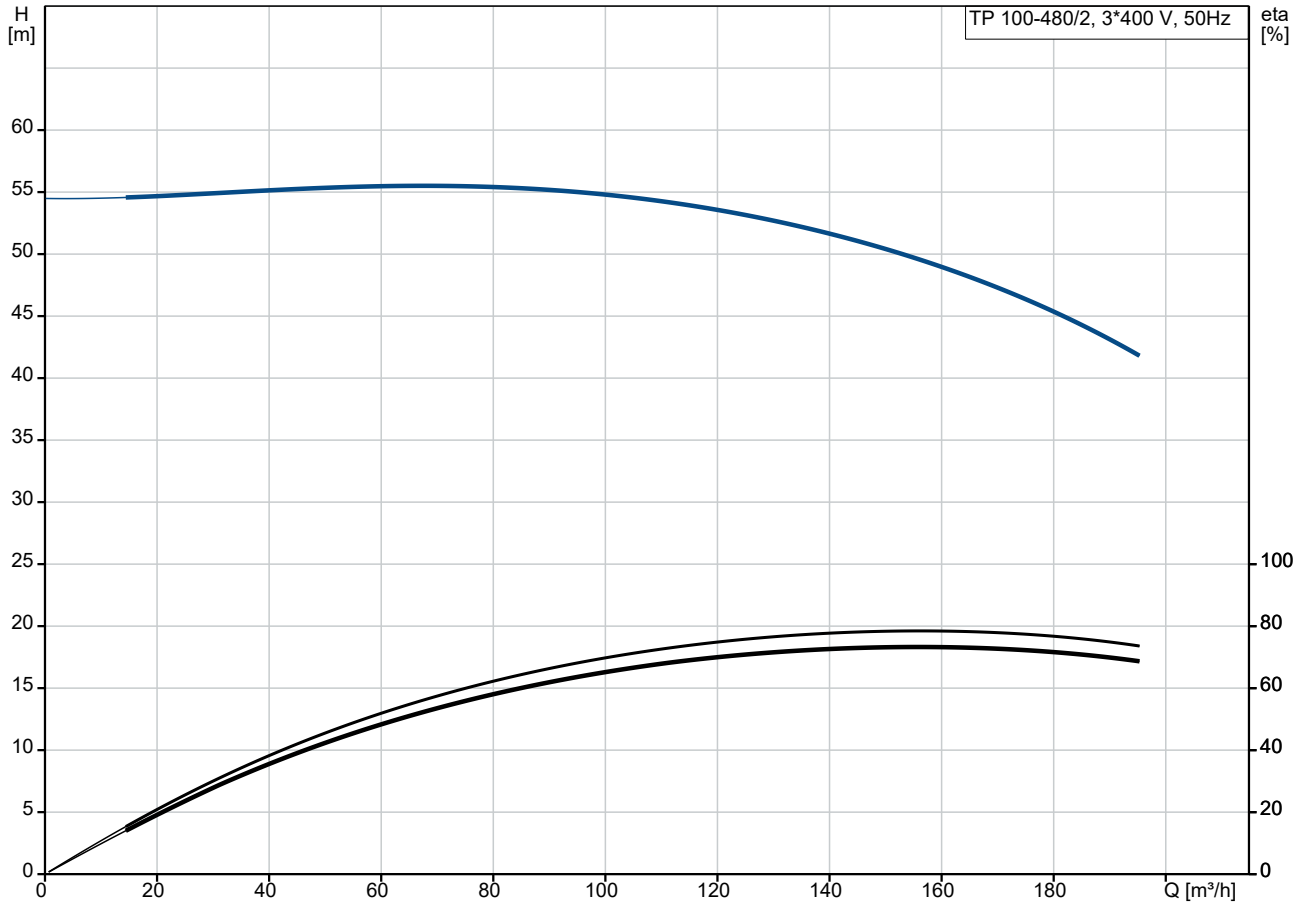

Pumped liquid = Water
Liquid temperature during operation = 20 °C
Density = 998.2 kg/m³

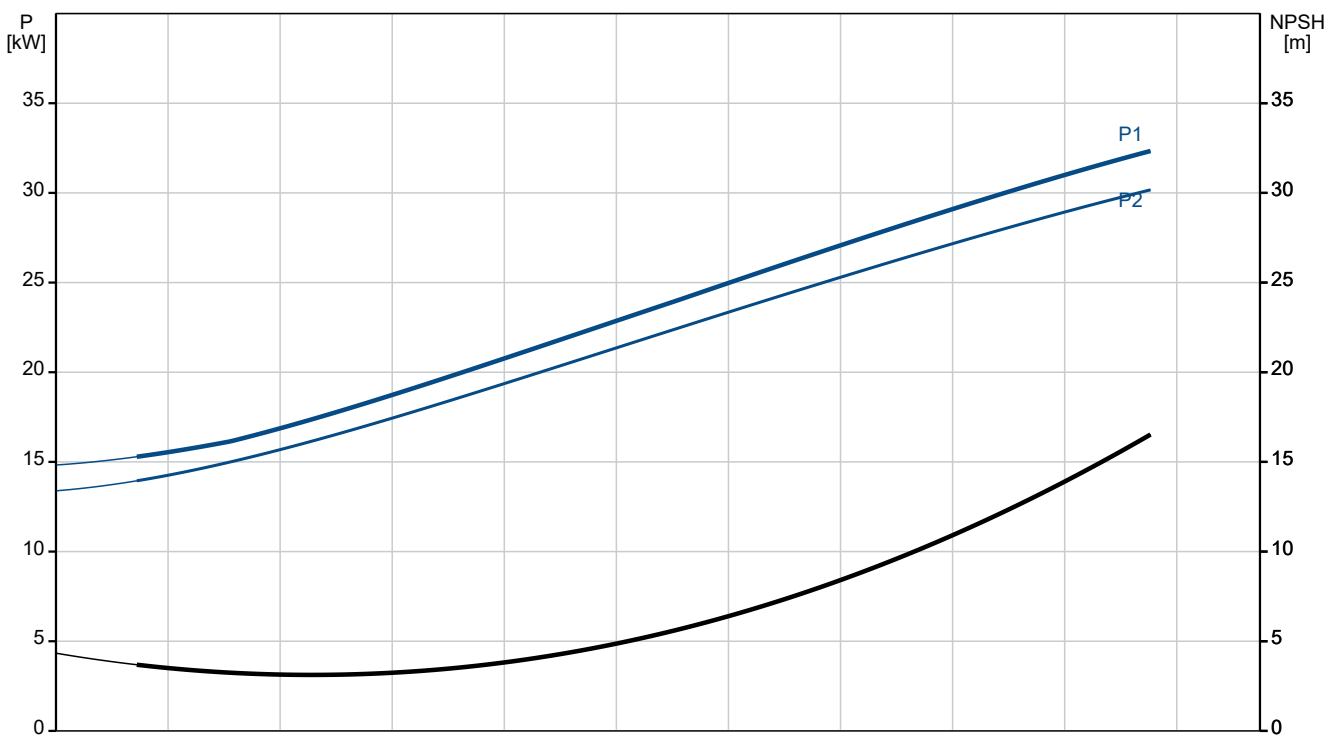

96109196 TP 100-480/2 A-F-A-BQQE-RW1 50 Hz

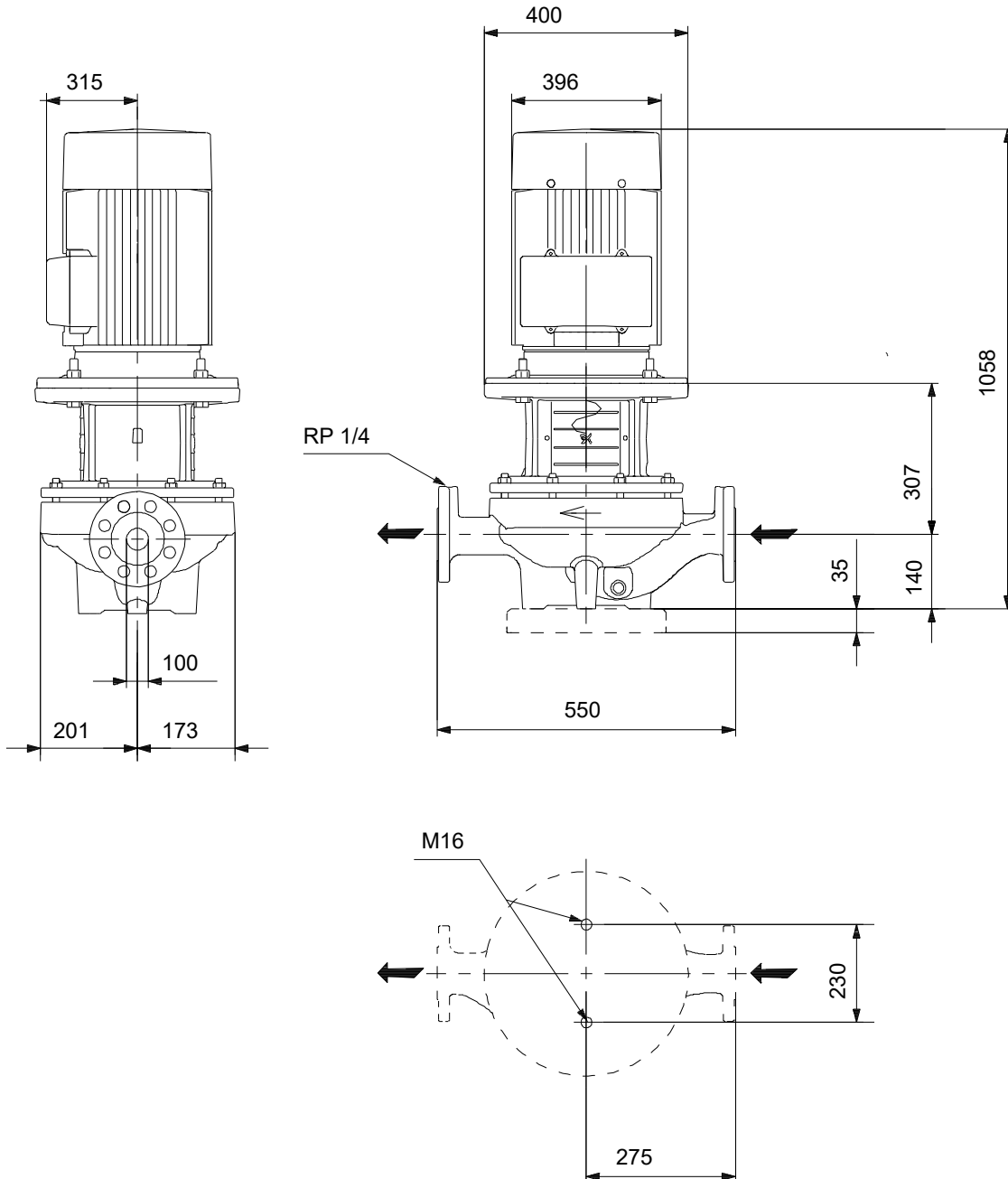

Note! All units are in [mm] unless others are stated.
Disclaimer: This simplified dimensional drawing does not show all details.